

.....
SUPER HIGH RESOLUTION
.....

600TVL

OWNER'S MANUAL

- Diagonal 6mm (1/3") Sony IT CCD
- Ultra High Resolution (600TVL)
- Selectable, Day & Night
- 3-Axis, Easy Install [Option]



COLOR CCD



DSP DIGITAL

CCD
DIGITAL COLOR



◎ USER INFORMATION



CAUTION

**RISK OF ELECTRIC SHOCK
DO NOT OPEN**



**CAUTION ! TO REDUCE THE RISK OF ELECTRIC SHOCK, DO NOT REMOVE COVER (OR BACK).
NO USER-SERVICEABLE PARTS INSIDE. REFER SERVICING TO QUALIFIED SERVICE
PERSONNEL.**



The lightning flash with arrowhead symbol, within an equilateral triangle, is intended to alert the user to the presence of un-insulated “dangerous voltage” within the product’s enclosure that may be of sufficient magnitude to constitute a risk of electric shock to persons.



The exclamation point within an equilateral triangle is intended to alert the user to the presence of important operating and maintenance-(servicing) instructions in the literature accompanying the appliance.

**THE GRAPHIC SYMBOLS WITH SUPPLEMENTAL MARKING ARE ON THE BOTTOM OF THE SYSTEM.
“WARNING-TO PREVENT FIRE OR SHOCK HAZARD, DO NOT EXPOSE THE UNIT TO RAIN OR MOISTURE.”**

○ USER INFORMATION

INFORMATION

This equipment has been tested and found to comply with limits for a Class A digital device, pursuant to part 15 of the FCC Rules.

These limits are designed to provide reasonable protection against harmful interference when the equipment is operated in a commercial environment.

This equipment generates, uses, and can radiate radio frequency energy and, if not installed and used in accordance with the instruction manual, may cause harmful interference to radio communications.

Operation of this equipment in a residential area is likely to cause harmful interference in which case the user will be required to correct the interference at their own expense.

WARNING

The manufacturer could void the user's authority to operate the equipment.

CAUTION

To prevent electric shock and risk of fire hazards:

- Do not use power sources except for that specified.
- Do not expose this appliance to rain or moisture.

This installation should be made by a qualified service person and should abide to all local codes.

◎ CONTENTS

Thank you for purchasing this COLOR VIDEO CAMERA.

Before using this camera, please read this operation manual carefully to obtain the best result and keep this manual for future reference.

1. SAFETY INSTRUCTIONS	5	8. COMMUNICATION PROTOCOL	28
2. PRECAUTIONS	6	9. OPERATING CAMERA	30
3. FEATURES	7	10. SPECIFICATION	48
4. COMPOSITION	8	12V DC Input Model	48
5. INSTALLATION	11	24V AC / 12V DC Input Model	50
6. NAME AND FUNCTIONS	18	11. TROUBLESHOOTING	52
7. CONNECTIONS	24		

◎ 1. SAFETY INSTRUCTIONS

Read Instructions

Read all of the safety and operating instructions before using the product.

Retain Instructions

Save this instructions for later use.

Cleaning

Unplug this appliance from wall outlet before cleaning. Do not use liquid cleaners or aerosol cleaners. Use a damp cloth for cleaning.

Water and Moisture.

Do not use this product near water or moisture. (For example. near a bathtub, wash bowl, kitchen sink, or laundry tub, in a wet basement, or near swimming pool, etc.)

Installation

Do not place this product on an unstable cart, stand, or table. The product may fall causing serious injury to a child or adult, and damage to the product.

Use only with a cart or stand recommended by the manufacturer, or sold with the product. Mounting should follow the manufacturer's instructions, and should use a mounting accessory recommended by manufacturer.

Power source

This product should be operated only from the type of power source indicated on the marking label.

If you are not sure of the type of power supplied to your home, consult your dealer or local power company.

2. PRECAUTIONS

- **Do not install the camera in extreme temperature conditions.**
Operate the camera under conditions where temperatures are within -10°C to 50°C . Especially be careful for ventilation under high temperature.
- **Do not install or use the camera in an environment where the humidity is high.**
It can cause the image quality to be poor.
- **Do not install the camera under unstable lighting conditions.**
Severe lighting change or flicker can cause the camera to work improperly.
- **Never use the camera close to a gas or oil leak.**
It can cause malfunctions to occur.
- **Do not disassemble the camera.**
There are no user repairable parts inside.
- **Do not drop the camera or subject them to physical shocks.**
It can cause malfunctions to occur.
- **Never keep the camera face to strong light directly.**
It can damage CCD.
- **Do not expose the camera to rain or spill liquid on it.**
If it gets wet, wipe it with dry cloth immediately.
Liquids can contain minerals that corrode the electronic components.



◎ 3. FEATURES

1. Diagonal 6mm (1/3") Sony IT CCD

2. Min Illumination(F1.2)

- 0.1 LUX (COLOR)
- 0.01 LUX (B/W)

3. High performance menus for functions

- Ultra High Resolution (600TVL)
- SBLC (Super Back Light Compensation)
- DNR (Digital Noise Reduction)
- Privacy zone selectable.
- Motion detection selectable.
- MIRROR (HORIZONTAL)
- Flickerless On/Off.

4. Selectable, day & night

- ICR(OPTIONAL)

5. RS-485 Communication Control Support (OPTIONAL)

- Remote OSD menu control via an RS-485 interface is supported.

◎ 4. COMPOSITION

▶ General Dome Camera [A, B Type]



▶ Service Monitor Cable



▶ UTP Harness Cable(Optional)



▶ Owner's Manual



▶ Guide Pattern



▶ Mounting Screw

▶ General Dome Camera [C Type]



▶ Service Monitor Cable



▶ UTP Harness Cable(Optional)



▶ Owner's Manual



▶ Guide Pattern



▶ Mounting Screw



Vandal proof Dome Camera



▶▶ Service Monitor Cable



▶▶ UTP Harness Cable (Optional)



▶▶ Owner's Manual



▶▶ Guide Pattern



▶▶ L-Wrench



▶▶ Mounting Screw



Flush Dome Camera [Flush type]

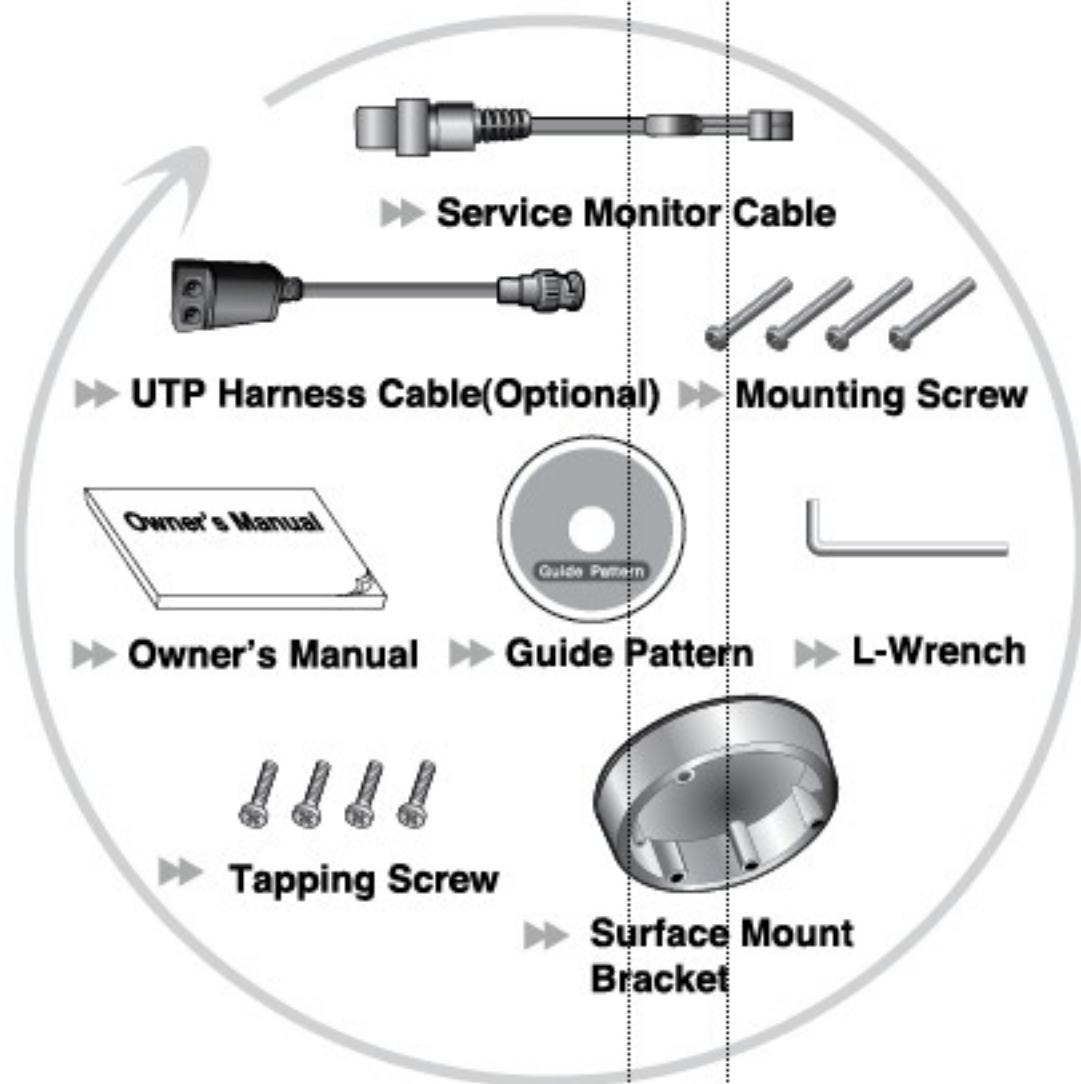

Flush Dome Camera [Surface type]

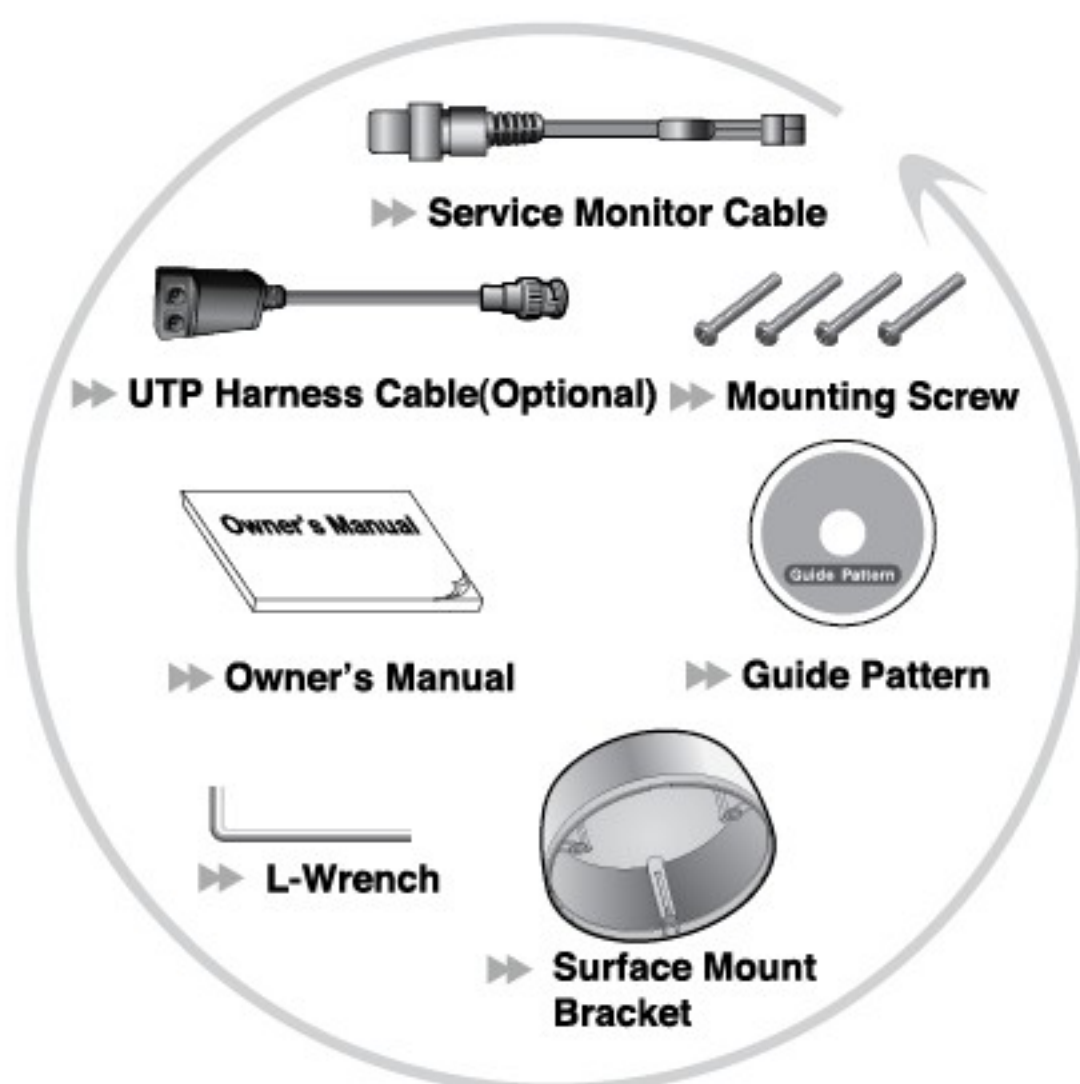

◎ 5. INSTALLATION

- 1 Stick the guide pattern on the wall or ceiling.
.....
- 2 Drill four holes according to the guide pattern then insert anchors into the drilled holes.
.....
- 3 Draw out power / video wires to the connecting places.
.....
- 4 Attach the camera base to the ceiling or wall using the supplied four screws.
.....
- 5 Adjust desired focus and scene by turning and moving the 3-axis camera bracket by hand.
.....
- 6 Align dome cover over base and snap into place to lock.
.....
- 7 Fix the dome cover on the base by covering.

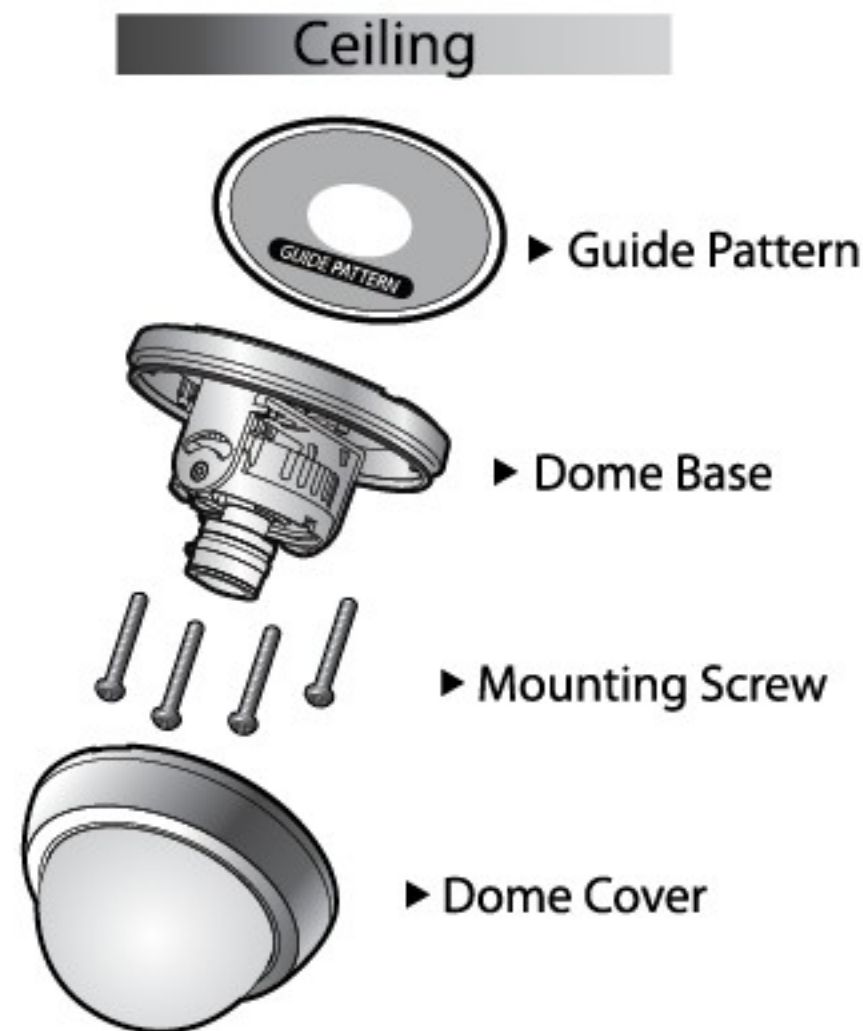

! **NOTE** Insert coin to the side hole and twist to remove dome cover

COLOR DOME CAMERA

General Dome Camera - [B] Type

- 1 Stick the guide pattern on the wall or ceiling.
.....
- 2 Drill four holes according to the guide pattern then insert anchors into the drilled holes.
.....
- 3 Draw out power / video wires to the connecting places.
.....
- 4 Attach the camera base to the ceiling or wall using the supplied four screws.
.....
- 5 Adjust desired focus and scene by turning and moving the 3-axis camera bracket by hand.
.....
- 6 Align dome cover over base and snap into place to lock.
.....
- 7 Fix the dome cover on the base by covering.
.....

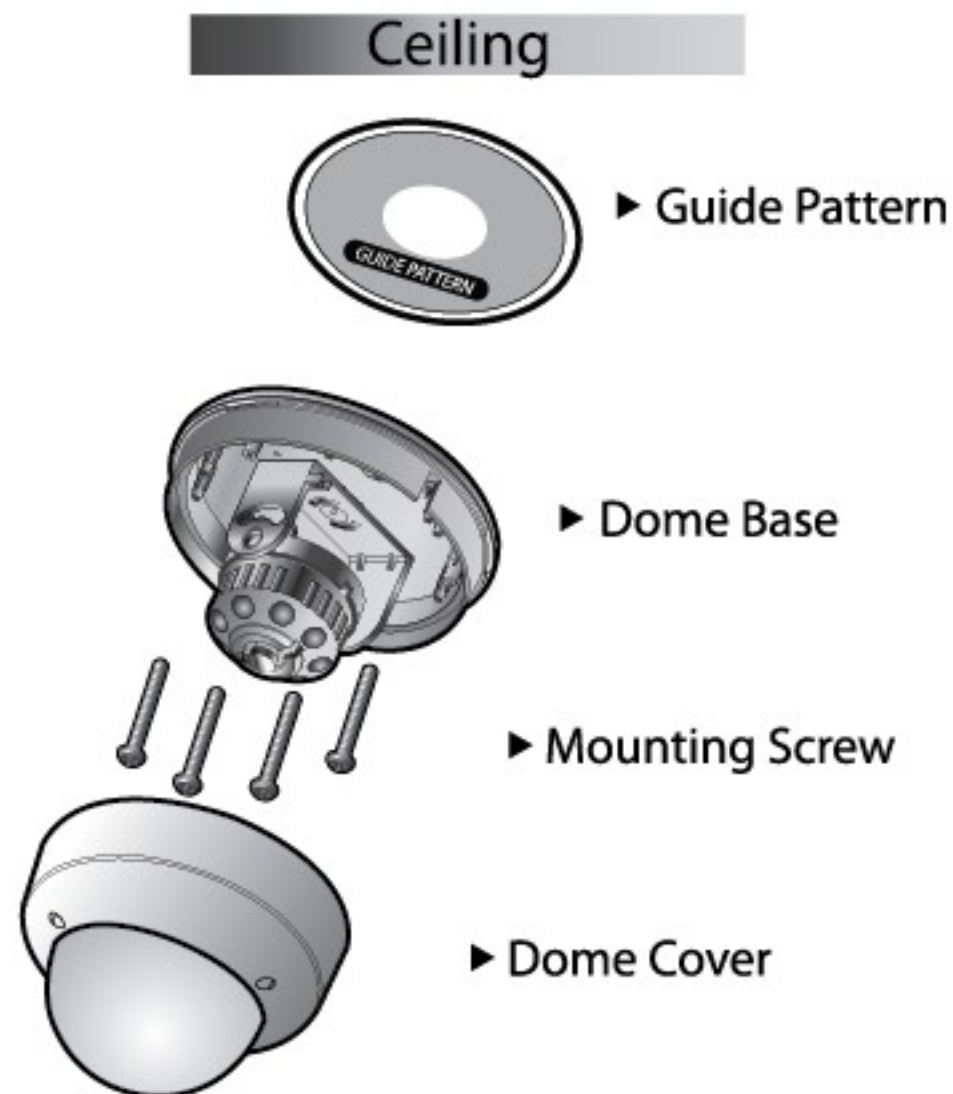

General Dome Camera -
[C] Type

- 1 Stick the guide pattern on the wall or ceiling.
.....
- 2 Drill four holes according to the guide pattern then insert anchors into the drilled holes.
.....
- 3 Draw out power / video wires to the connecting places.
.....
- 4 Attach the camera base to the ceiling or wall using the supplied three screws.
.....
- 5 Cover the camera bracket with inner dome after adjust desired focus and scene by turning and moving 3-axis by hand
.....
- 6 Adjust desired focus and scene by turning and moving the 3-axis camera bracket by hand.
.....
- 7 Align dome cover over base and snap into place to lock.
.....
- 8 Fix the dome cover on the base by covering.
.....

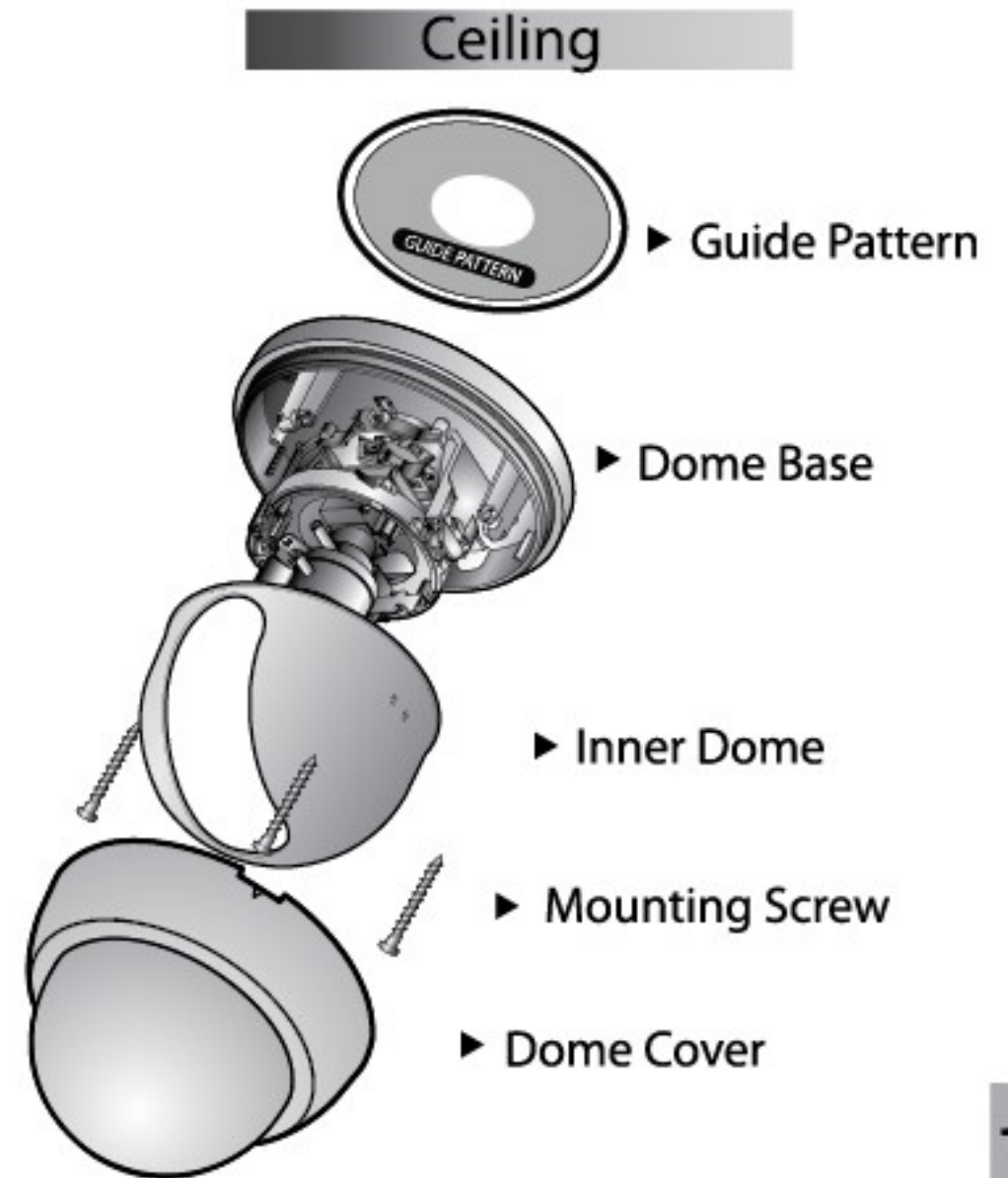

Vandal Proof Dome Camera

- 1 Stick the guide pattern on the wall or ceiling.
.....
- 2 Drill four holes according to the guide pattern then insert anchors into the drilled holes.
.....
- 3 Draw out power / video wires to the connecting places.
.....
- 4 Attach the camera base to the ceiling or wall using the supplied four screws.
.....
- 5 Adjust desired focus and scene by turning and moving the 3-axis camera bracket by hand.
.....
- 6 Put the dome cover over the base.
.....
- 7 Fix the dome cover on the base by L-Wrench.
.....

Ceiling

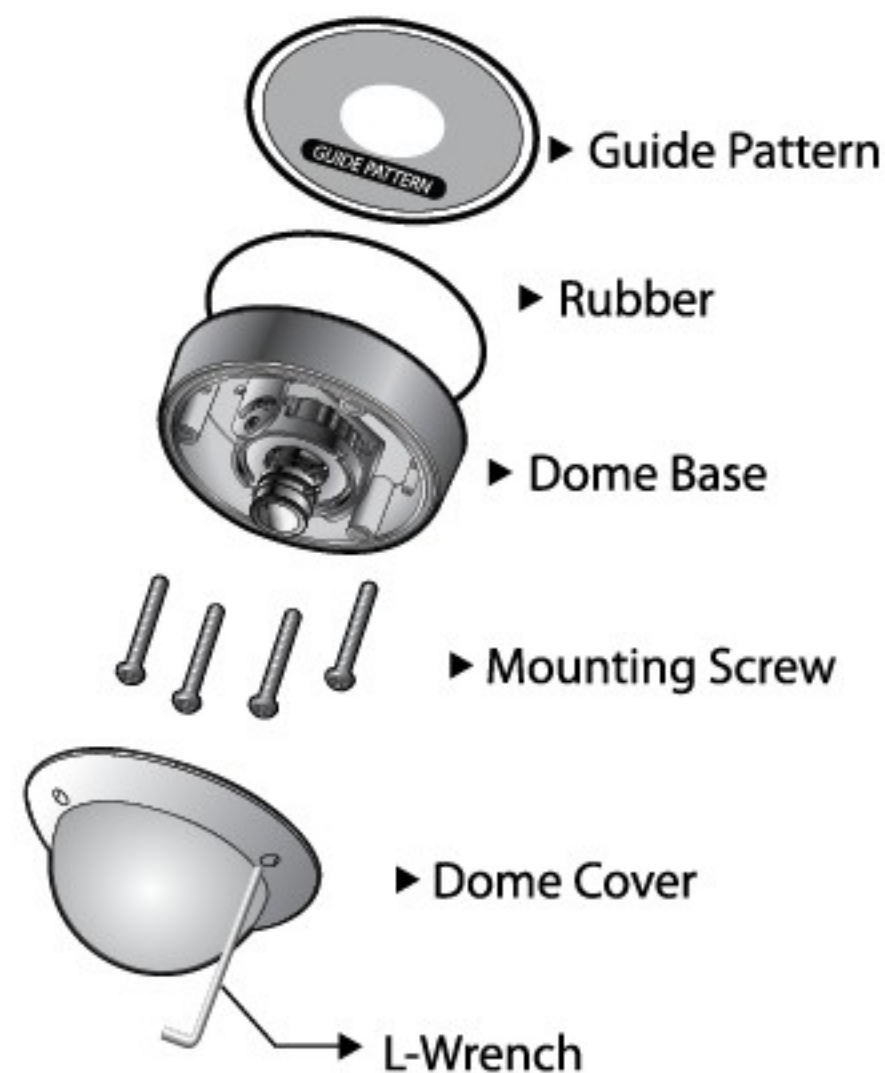

**Flush Vandal Proof
Dome Camera**

Ceiling

- 1 Stick the guide pattern on the wall or ceiling.
.....
- 2 Drill four holes according to the guide pattern then insert anchors into the drilled holes.
.....
- 3 Fix the surface mount bracket by screws on the ceiling.
.....
- 4 Draw out power / video wires to the connecting places.
.....
- 5 Connect the dome base to the surface mount bracket by screws.
.....
- 6 Adjust desired focus and scene by turning and moving the 3-axis camera bracket by hand.
.....
- 7 Put the dome cover over the base.
.....
- 8 Fix the dome cover on the base by L-Wrench.
.....

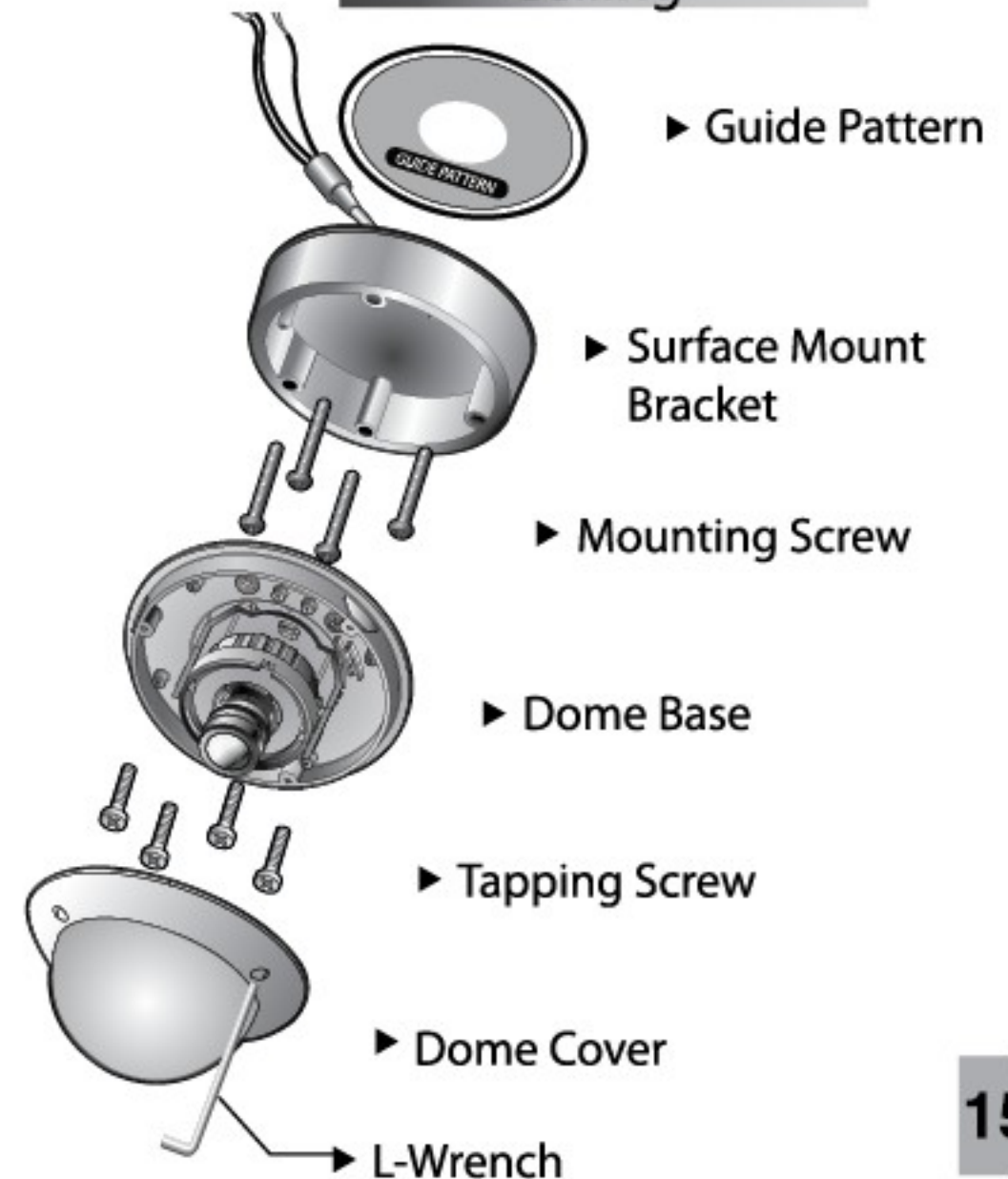

COLOR DOME CAMERA

Flush Dome Camera [Flush Type]

- 1 Stick the guide pattern on the wall or ceiling.
- 2 Drill hole according to the guide pattern and remove Surface Mount Bracket then insert dome camera base into the drilled holes.
- 3 Draw out power / video wires to the connecting places.
- 4 Tighten three screws until it dose not turn to fix the camera on the ceiling
- 5 Cover the camera bracket with inner dome after adjust desired focus and scene by turning and moving 3-axis by hand

- 6 Put the dome cover over the base until it clicks.



Push both side of the Surface Mount Bracket by hand to release.

Ceiling

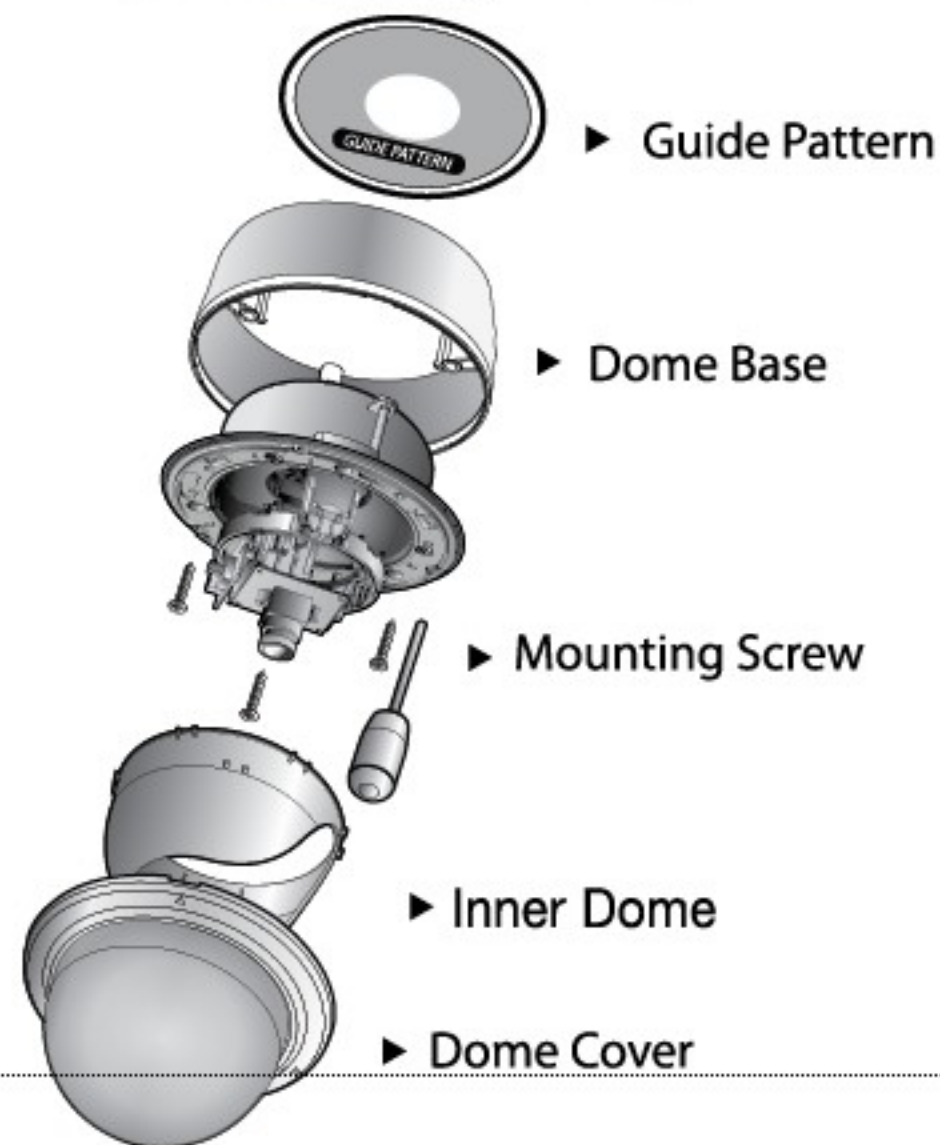

Flush Dome Camera
[Surface Type]

- 1 Stick the guide pattern on the wall or ceiling.
- 2 Drill three hole according to the guide pattern then insert anchors into the drilled holes.
- 3 Draw out power / video wires to the connecting places.
- 4 Fixed the camera to a ceiling using three mounting screws.
- 5 Cover the camera bracket with inner dome after adjust desired focus and scene by turning and moving 3-axis by hand
- 6 Put the dome cover over the base until it clicks.

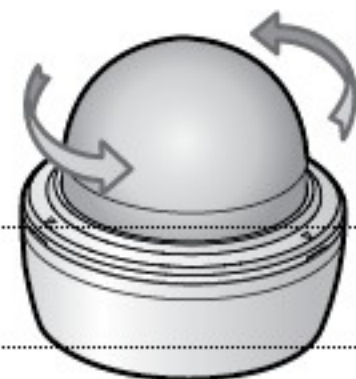

! Turn the dome cover counter clock wise to remove from the main body.

Ceiling

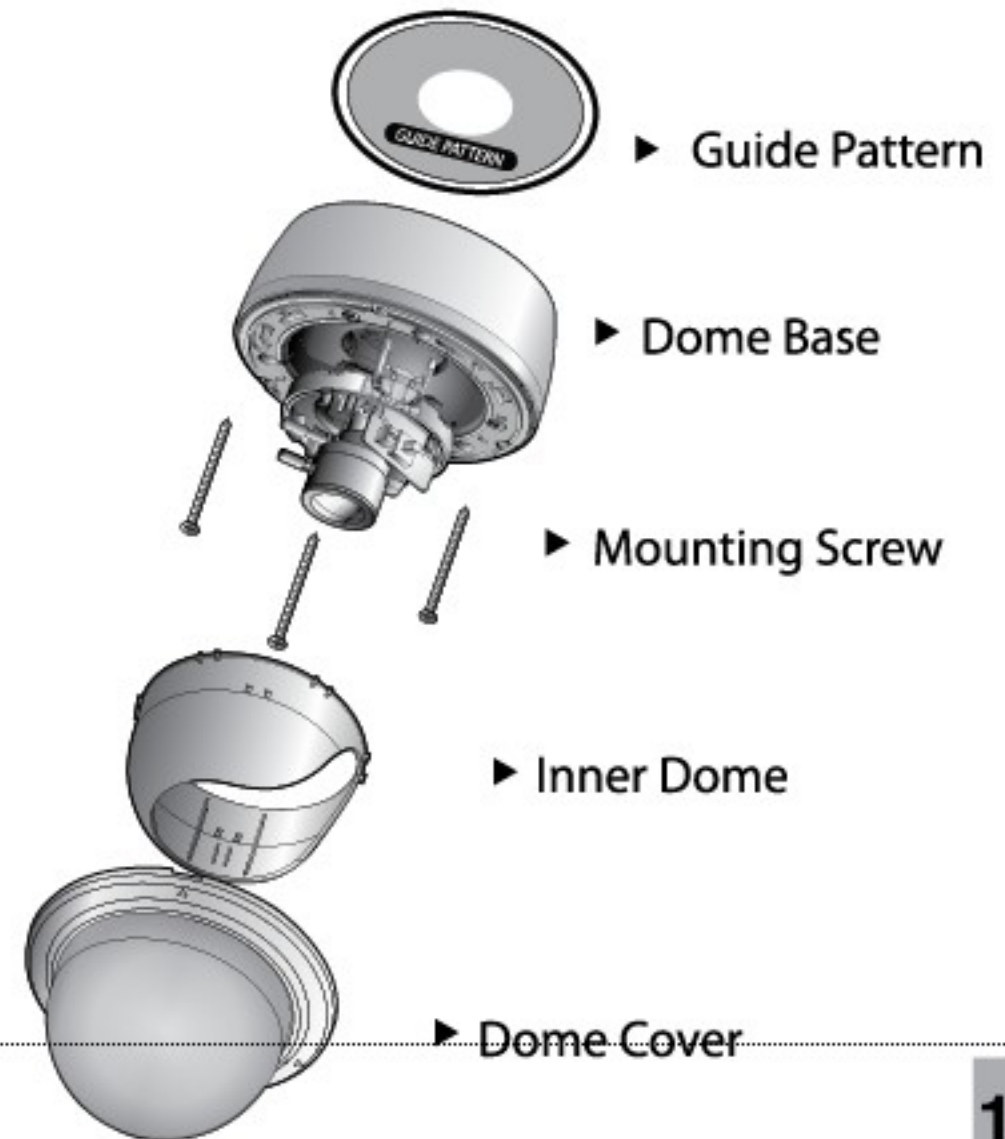

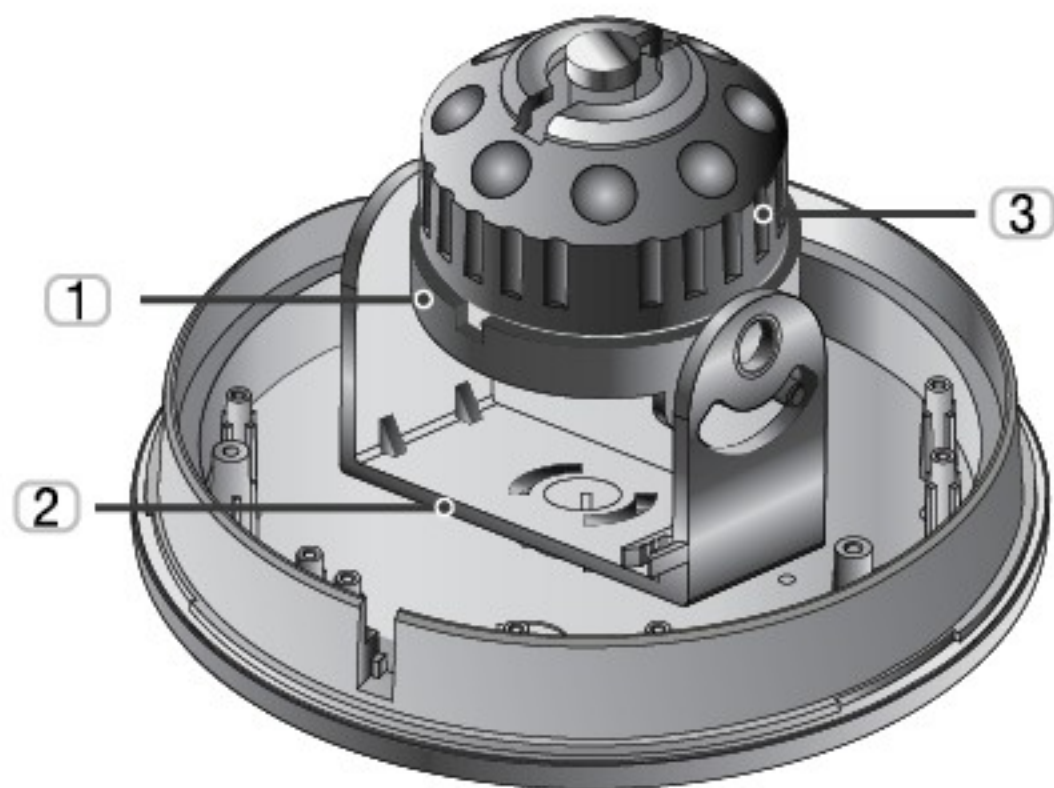

Camera Lay-out

- 1 Tilt rotation : Adjusting the vertical angle.
- 2 Pan rotation : Adjusting the horizontal angle.
- 3 Horizontal rotation : Adjusting the horizontal position of the screen.

Vari-focal Lens Type

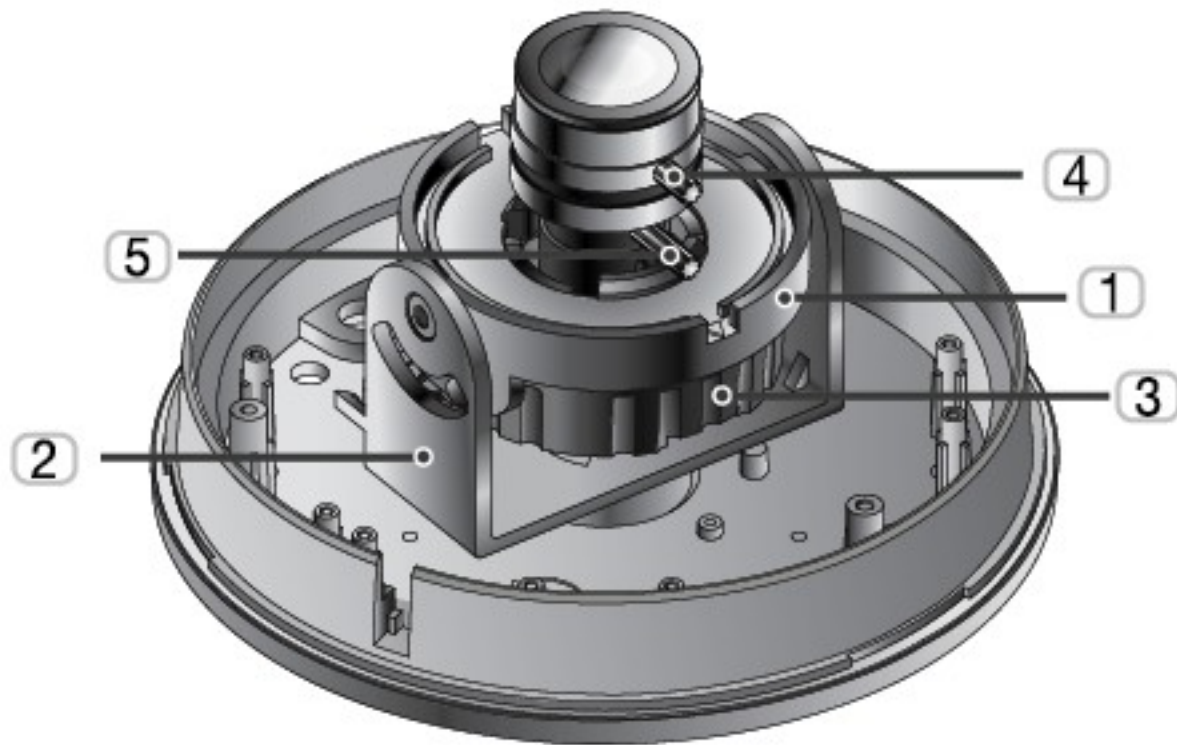

Camera Lay-out

- ① Tilt rotation : Adjusting the vertical angle.
- ② Pan rotation : Adjusting the horizontal angle.
- ③ Horizontal rotation : Adjusting the horizontal position of the screen.
- ④ Focus handle : Focus (Far or Near)
- ⑤ Zoom handle : Zoom (Tele or Wide)

Fixed Lens Type

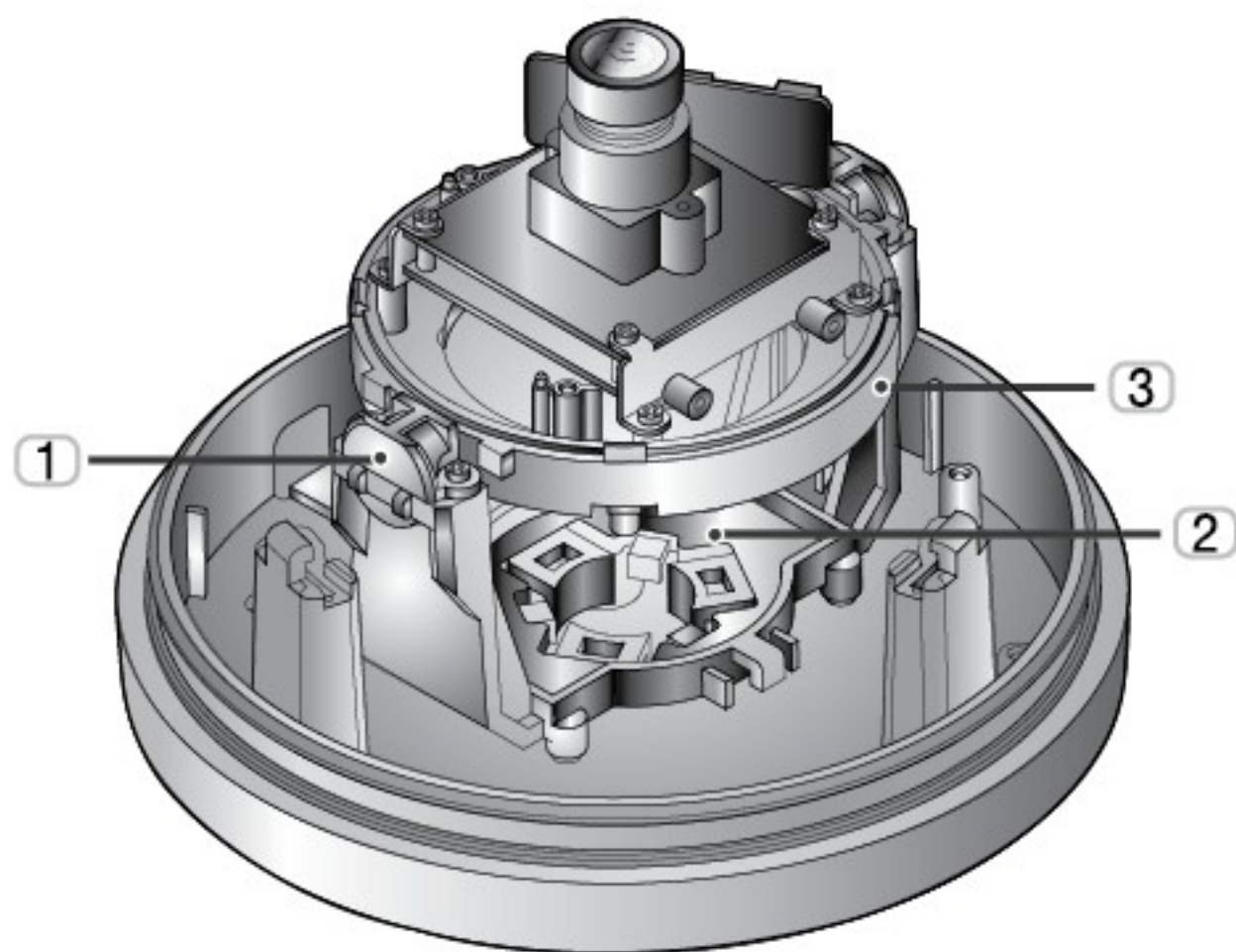

Camera Lay-out

- 1 Tilt rotation : Adjusting the vertical angle.
- 2 Pan rotation : Adjusting the horizontal angle.
- 3 Horizontal rotation : Adjusting the horizontal position of the screen.

Vari-focal Lens Type

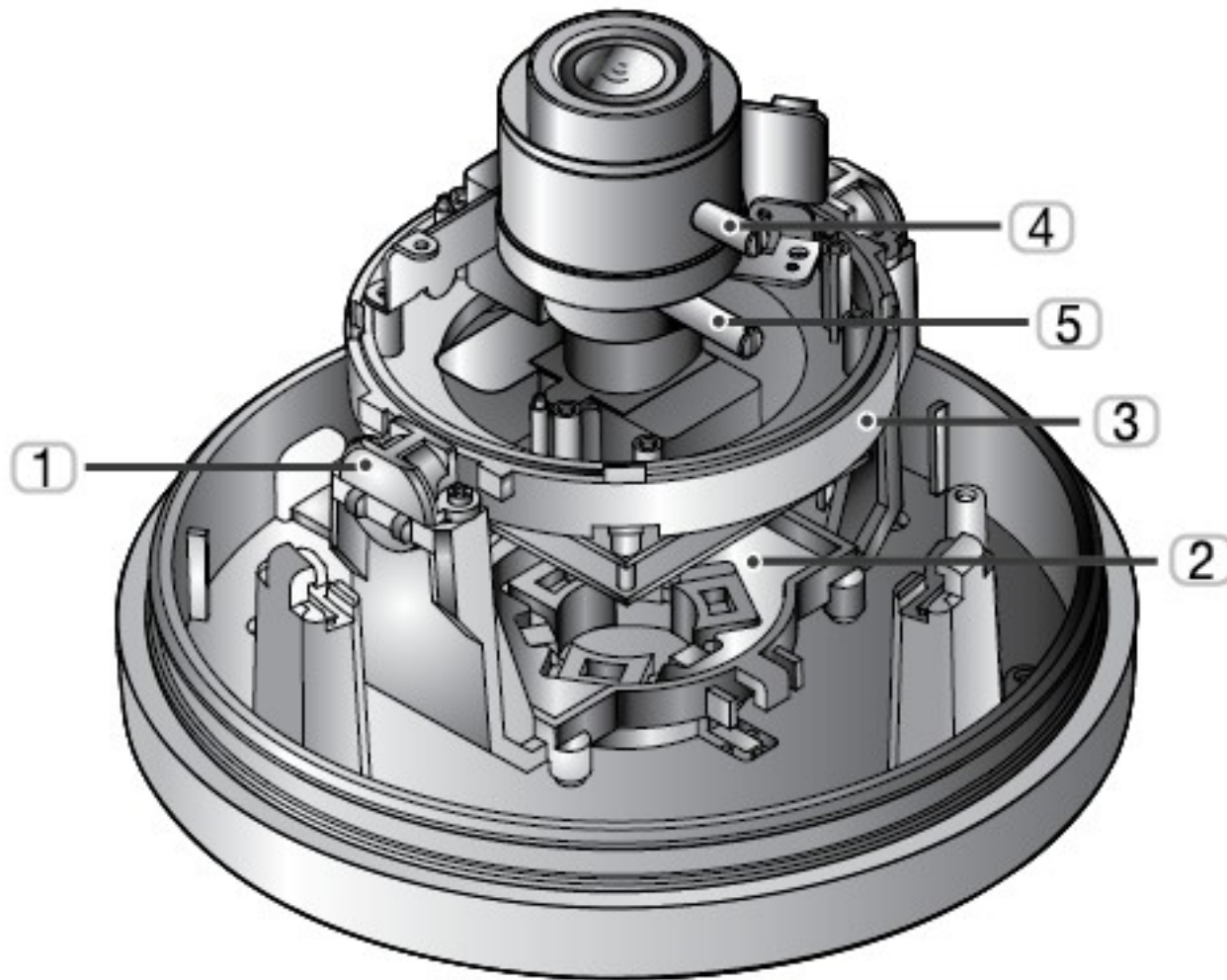

Camera Lay-out

- ① Tilt rotation : Adjusting the vertical angle.
- ② Pan rotation : Adjusting the horizontal angle.
- ③ Horizontal rotation : Adjusting the horizontal position of the screen.
- ④ Focus handle : Focus (Far or Near)
- ⑤ Zoom handle : Zoom (Tele or Wide)

COLOR DOME CAMERA

Fixed Lens Type [Flush Dome Camera]

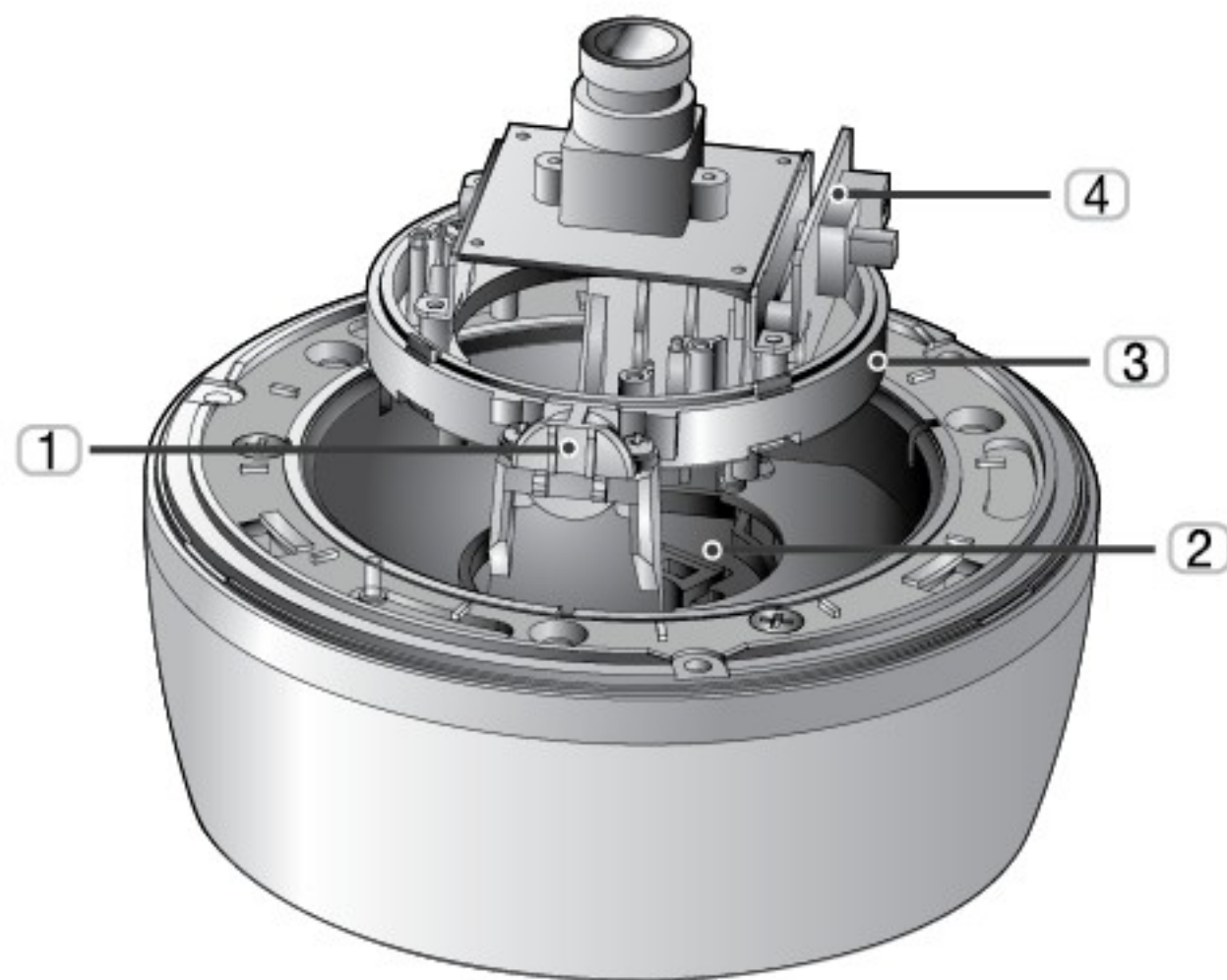

Camera Lay-out

- ① Tilt rotation : Adjusting the vertical angle.
- ② ③ Pan rotation : Adjusting the horizontal angle.
- ④ Horizontal rotation : Adjusting the horizontal position of the screen.

Vari-focal Lens Type
[Flush Dome Camera]

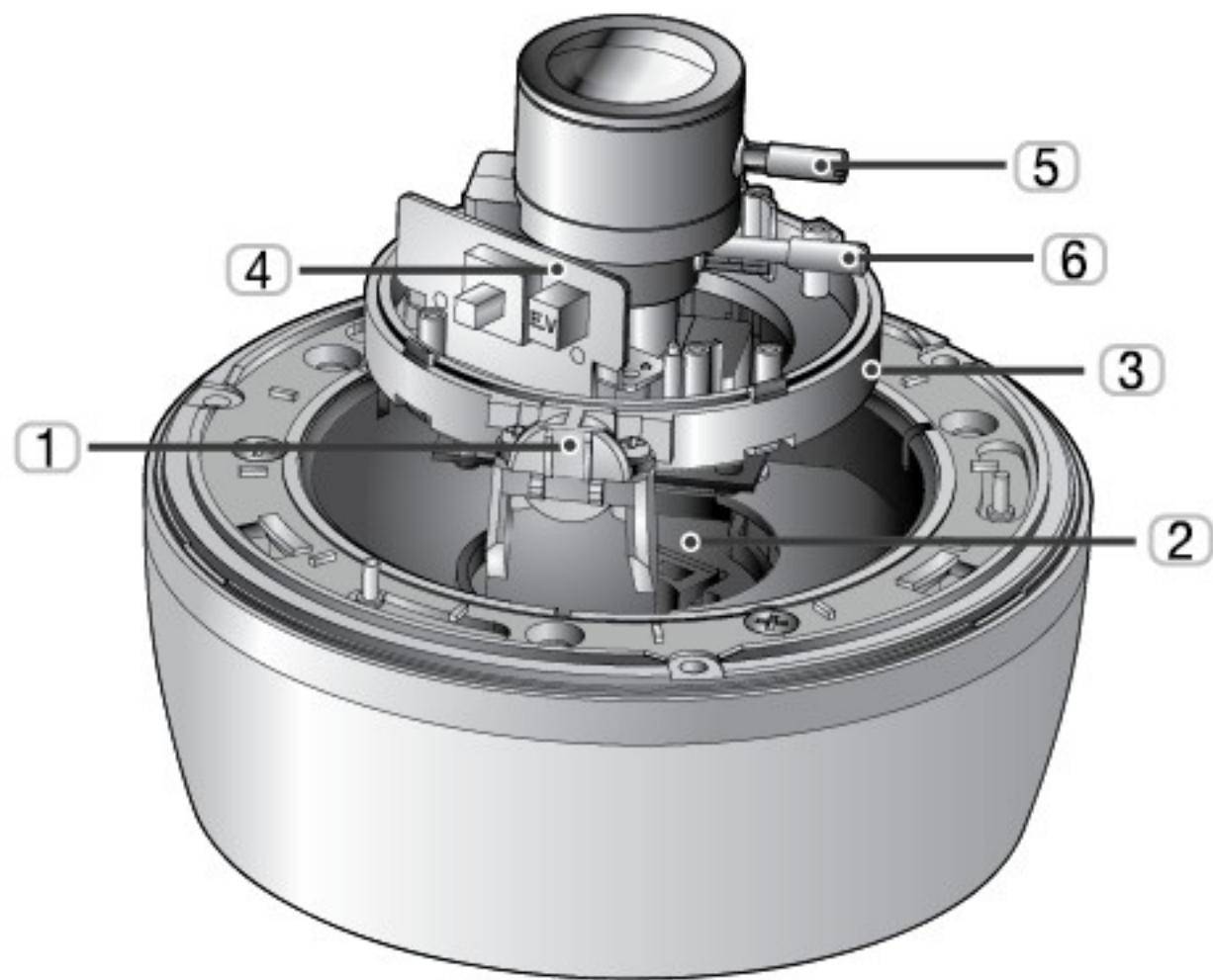

▶ Camera Lay-out

- ① Tilt rotation : Adjusting the vertical angle.
- ② ③ Pan rotation : Adjusting the horizontal angle.
- ④ Horizontal rotation : Adjusting the horizontal position of the screen.
- ⑤ Focus handle : Focus (Far or Near)
- ⑥ Zoom handle : Zoom (Tele or Wide)

7. CONNECTIONS

1. Connecting to Monitor and Power

● **For 24V AC / 12V DC Power Type**

- The wire is non-polarized.
- Use 24V AC \sim power source or 12V DC --- power source.
- Use the power rated at least 3.6W / 24VAC and 0.3A (12VDC)

NO	Function	Terminal Color	Remark
#1	Video Output	Yellow	1.0 Vp.p
#2	Power Input	Green	24V AC(20V~28V)or 12V DC(11V~15V), Max 3.6W / 0.3A

● **For 12V DC Power Type**

- Connect the video-out jack to the video-in jack of monitor.
- Connect the power adapter to the power input connecter.
- Use 12V DC --- power source.
- Use the power rated at least 180mA (12VDC)

NO	Function	Terminal Color	Remark
#1	Video Output	Yellow	1.0 Vp.p
#2	Power Input	Red	12V DC(10V~15V), Max 2.2W /180mA

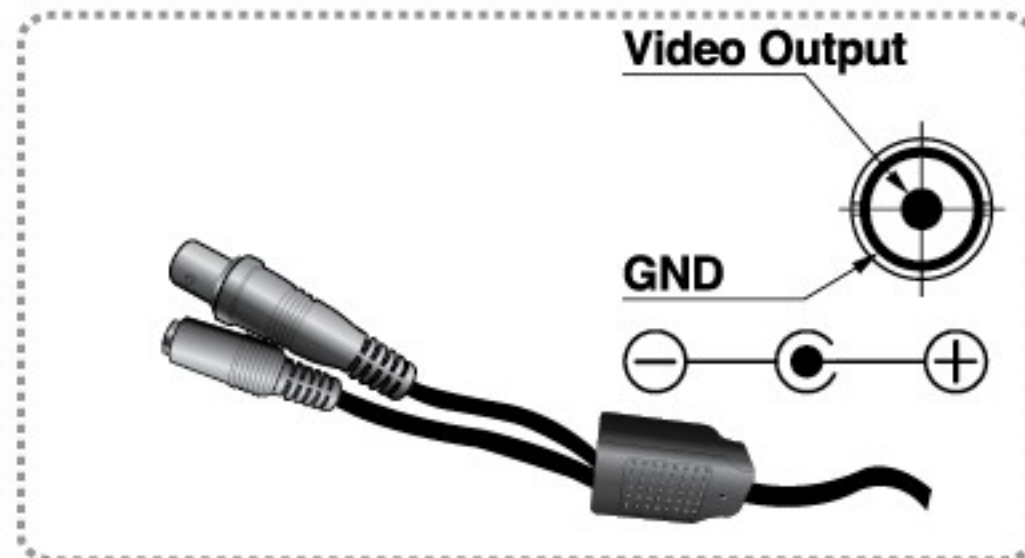
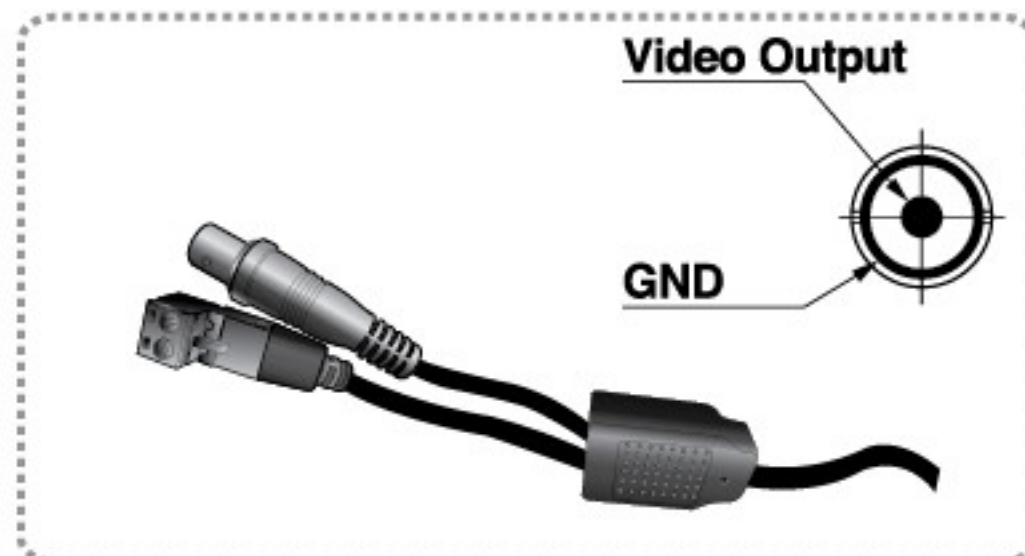

2. UTP (Unshielded Twisted Pair)

- For 24V AC Power Type [UTP Video Output]

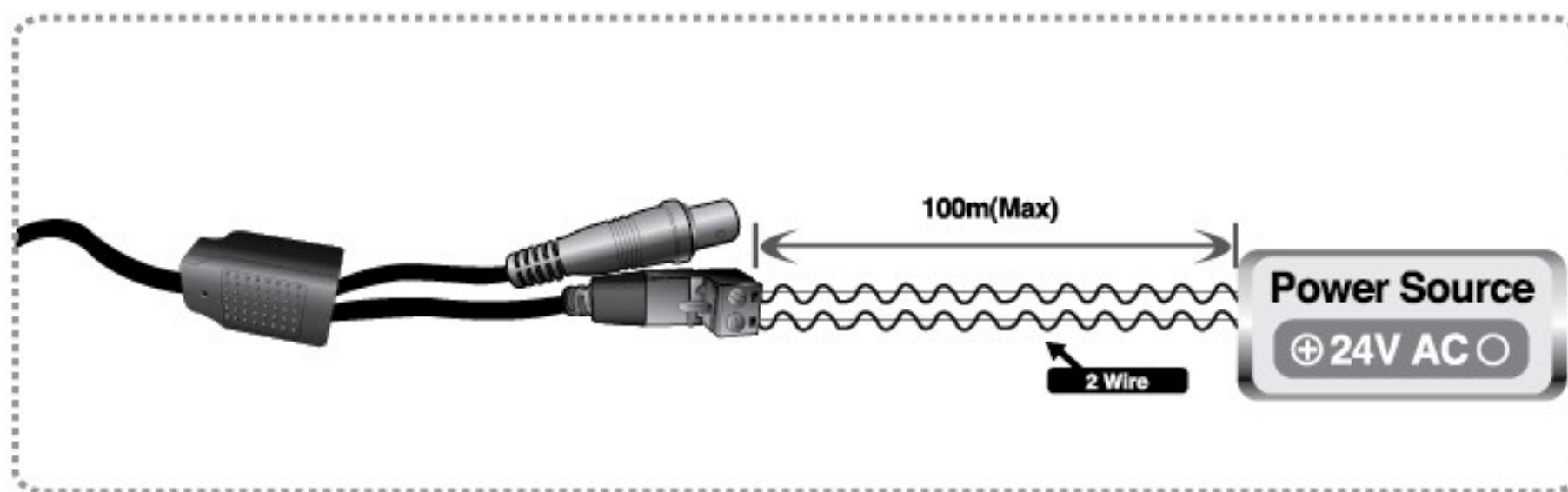

- When using 24V AC power, it is possible to supply the power within 100m.
- Use 4 wires by 2 pair of wires.
- When using 12V DC power, UTP should not be used as the power.

● Connecting to Monitor

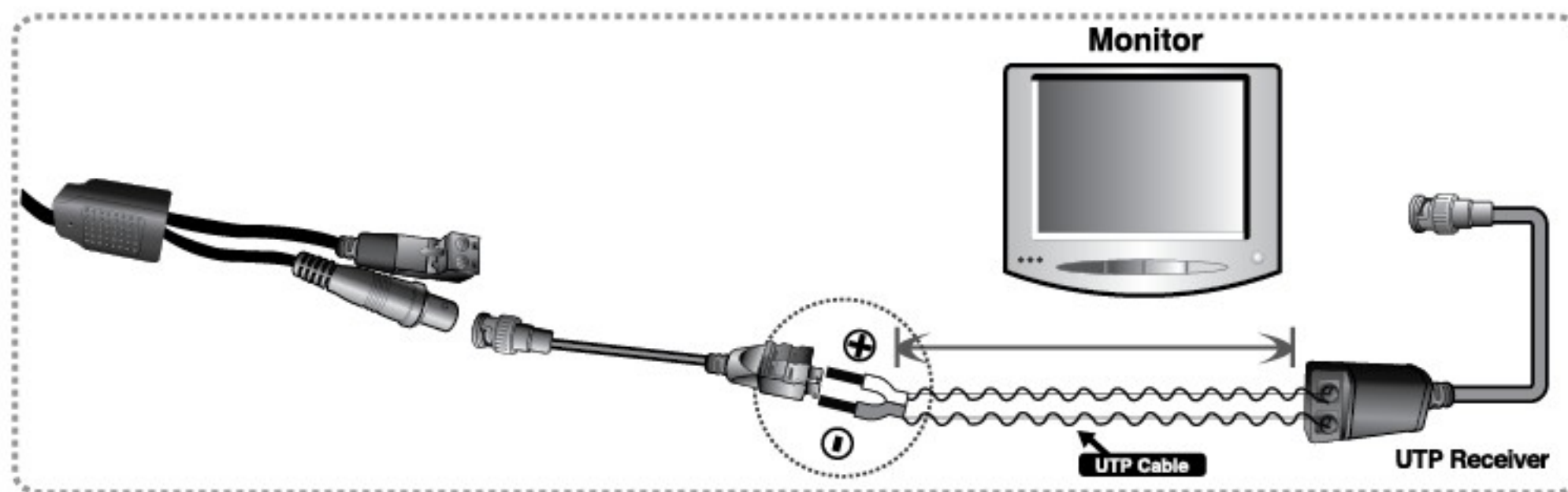

- Connect UTP(Unshielded Twisted Pair) wire to the UTP output of the camera directly. UTP transmitter is included in the camera therefore additional UTP transmitter is not necessary.
- UTP receiver is necessary to connect UTP wire to Monitor or DVR
- When connecting UTP wire, make sure the polarity of the video signal is correct.
- Use UTP wire "CAT5 24AWG" to have the best transmission quality.
- The twisted-pair output cannot be used at the same time as the Composite Video output

3. Camera remote control connecting (Optional)

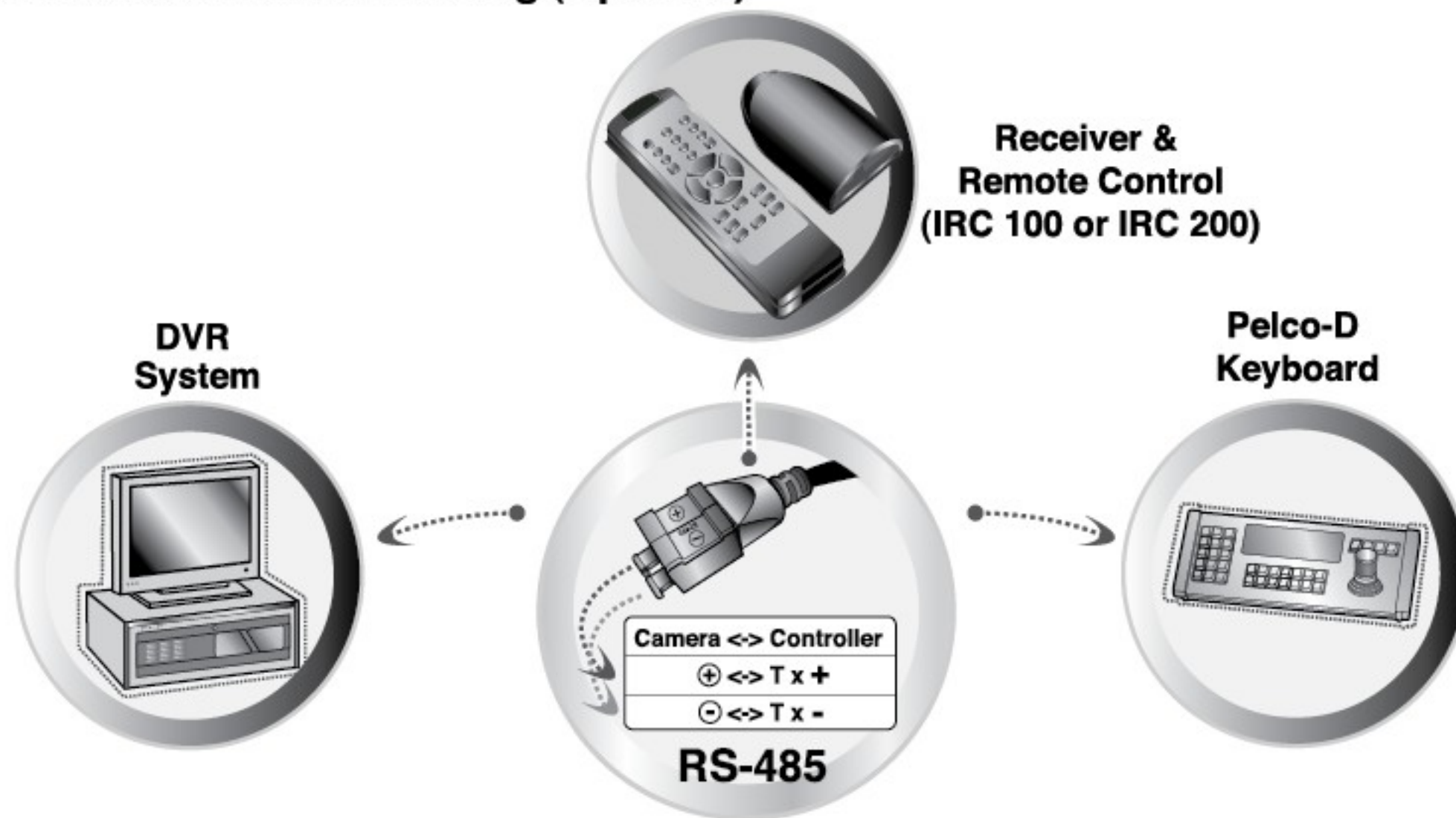

8. COMMUNICATION PROTOCOL

PELCO "D" Byte Format

Function	KEY UP						
	1 BYTE	2 BYTE	3 BYTE	4 BYTE	5 BYTE	6 BYTE	7 BYTE
MSG	0xFF	ID	0x00	0x20	0x00	0x00	CS
Function	KEY DOWN						
	1 BYTE	2 BYTE	3 BYTE	4 BYTE	5 BYTE	6 BYTE	7 BYTE
MSG	0xFF	ID	0x00	0x40	0x00	0x00	CS
Function	KEY LEFT						
	1 BYTE	2 BYTE	3 BYTE	4 BYTE	5 BYTE	6 BYTE	7 BYTE
MSG	0xFF	ID	0x01	0x00	0x00	0x00	CS
Function	KEY RIGHT						
	1 BYTE	2 BYTE	3 BYTE	4 BYTE	5 BYTE	6 BYTE	7 BYTE
MSG	0xFF	ID	0x00	0x80	0x00	0x00	CS

Function	OSD MENU ON/OFF (Pelco)						
	1 BYTE	2 BYTE	3 BYTE	4 BYTE	5 BYTE	6 BYTE	7 BYTE
M S G	0xFF	ID	0x00	0x23	0x00	0x5F	CS
Function	OSD MENU ON/OFF (Bido Pelco System)						
	1 BYTE	2 BYTE	3 BYTE	4 BYTE	5 BYTE	6 BYTE	7 BYTE
M S G	0xFF	ID	0x00	0x03	0x00	0x62	CS
Function	OSD MENU ON/OFF (CNB DVR)						
	1 BYTE	2 BYTE	3 BYTE	4 BYTE	5 BYTE	6 BYTE	7 BYTE
M S G	0xFF	ID	0x40	0x00	0x00	0x00	CS

ID = 01hex ~ FFhex : ID check mode

NOTE

(Camera will check the camera ID. If the ID contained in command packet isn't identical to the current camera ID, the received command will be ignored and deleted.)

◎ 9. OPERATING CAMERA

LENS	ESC	BRIGHTNESS	0~20
		FLK	OFF, ON
	DC	DC LEVEL	0~20
		FLK	OFF, ON
	SHUTTER	1/60(1/50), 1/120(1/100), 1/250, 1/500, 1/700, 1/1K, 1/1600, 1/2500 1/5K, 1/7K, 1/10K, 1/30K, 1/60K, 1/120K	
WHITE BAL	ATW		
	MANUAL	RED	0~160
		BLUE	0~160
PUSH			
AGC	ON	LEVEL	0~20
	OFF		
DAY / NIGHT	COLOR		
	B/W	BURST	OFF, ON
	EXT		
	AUTO	DELAY TIME	1~15

IMAGE ADJ	SBLC	OFF, LOW, MIDDLE, HIGH		
	DNR	OFF, LOW, MIDDLE, HIGH		
	SHARPNESS	LEVEL	0~20	
	MIRROR	OFF, ON		
	MOTION	AREA		1~4
		DISPLAY		OFF, ON
		SENSITIVITY		1~24
		TOP		8~126
		BOTTOM		8~126
		LEFT		4~191
		RIGHT		4~191
		INITIAL		OFF ←, ON
		RETURN		←
	PRIVACY	AREA		1~4
		DISPLAY		OFF, ON
		COLOR		WHITE, YELLOW, GREEN, BLUE, RED, BLACK, GRAY
		TOP		4~63
		BOTTOM		5~64
		LEFT		18~205
RIGHT			19~206	
INITIAL			OFF ←, ON	
RETURN		←		

IMAGE ADJ	COLOR GAIN	R-Y	0~20
		B-Y	0~20
	INITIAL		OFF ←, ON
	RETURN		←
GENERAL	CAM ID		0~255
	ID DISPLAY		OFF, ON
	CAM TITLE	OFF	
		ON	UP/ DN, LE/ RI
	LANGUAGE		ENG, CHN(PAL)
	SYNC		INT
	BAUDRATE		2400, 4800, 9600, 57600
	VERSION		
	INITIAL		OFF ←, ON
RETURN		←	
INITIAL			OFF ←, ON
RETURN			←

Use the joystick to navigate between 5 ways.

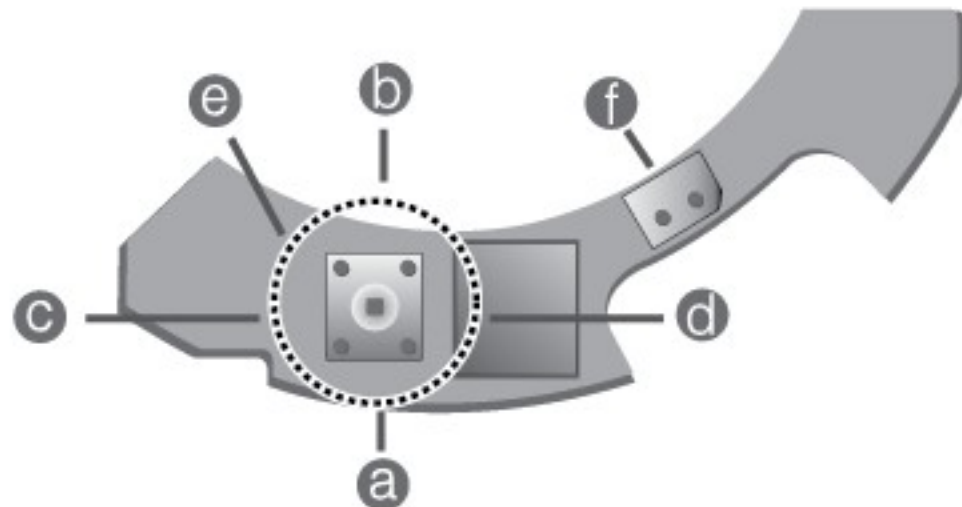

- a** DOWN : Move down / **b** UP : Move up
- c** LEFT : Move left
- d** RIGHT : Move right
- e** MENU(SET):
Press the joystick in its straight position.
- f** Service Monitor Connector :
Use service monitor connector to set camera angle & focus when installing.
(Image cannot be seen if monitor output and service video output is used simultaneously.)

MAIN MENU - GENERAL

Press MENU button to access the SETUP menu.

Select each sub-menu by using the ◀, ▶, ▲, ▼ button.
Press the MENU(SET) button to select.

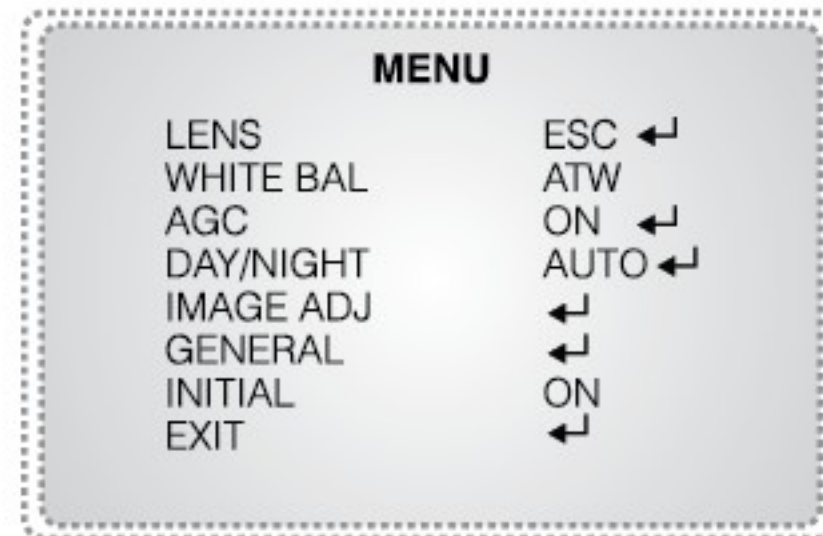

If the OSD MENU is changed then INITIAL will be OFF ◀
(EXCEPT : LENS, CAM ID, BAUDRATE)

LENS

Press the MENU button to access the SETUP menu.

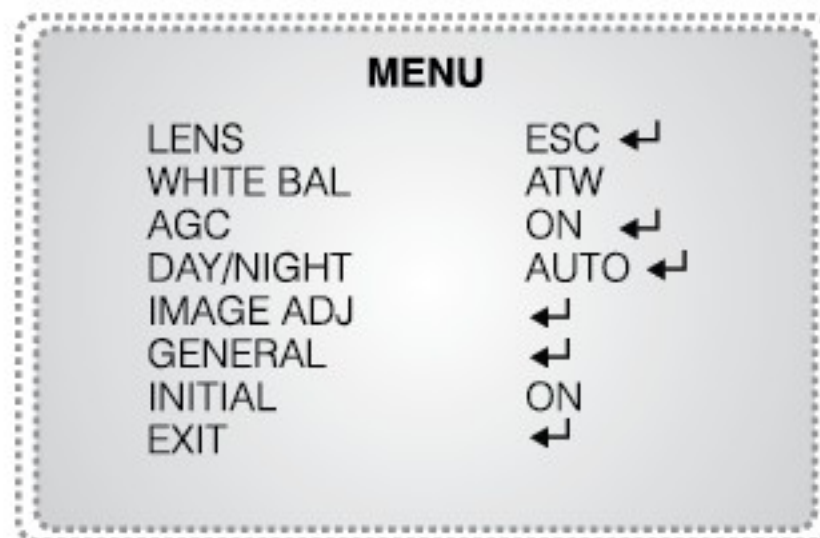

LENS ESC

- Select LENS using the UP or DOWN button. You can change between ESC and DC using the LEFT or RIGHT button.

Select ESC and Press MENU button to display LENS ESC.

1. BRIGHTNESS

- Select BRIGHTNESS using the UP or DOWN button. You can adjust between 0 ~ 20 using the LEFT or RIGHT button.

2. FLK (FLICKERLESS)

- Select FLK using the UP or DOWN button. You can select between ON / OFF using the LEFT or RIGHT button.
- Hint: Press Menu to go back to Main Menu.

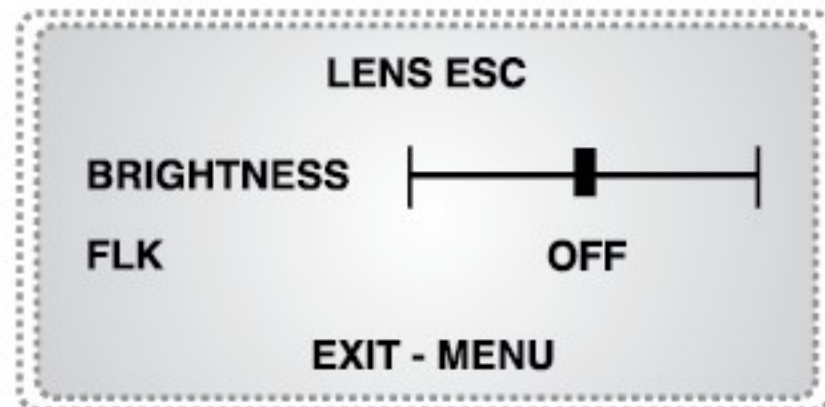

LENS DC

Select DC and Press the MENU button to have LENS DC activated .

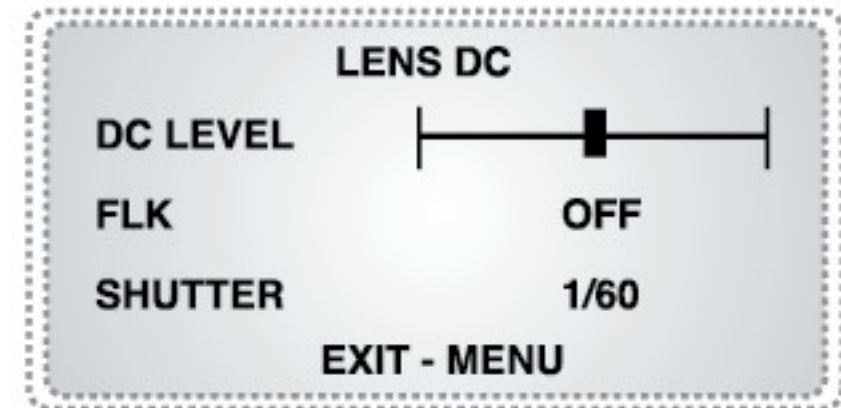
**1. DC LEVEL(Adjusts brightness of the image.)**

- Select DC LEVEL using the UP or DOWN button. You can adjust between 0 ~ 20 level using the LEFT or RIGHT button.

2. FLK (FLICKERLESS)

- Select FLK using the UP or DOWN button. You can select between ON / OFF using the LEFT or RIGHT button.

> OFF : You will be allowed to adjust the shutter speed.

3. SHUTTER (Adjusts the shutter speed of the lens.)

- Select SHUTTER using the UP or DOWN button. You can adjust from 1/60(1/50), 1/120(1/100), 1/250, 1/500, 1/700, 1/1K, 1/1600, 1/2500, 1/5K, 1/7K, 1/10K, 1/30K, 1/60K, 1/120K(sec) level using the LEFT or RIGHT button.

WHITE BAL (White Balance)

Select **WHITE BAL** using the **UP** or **DOWN** button. You can select from **ATW**, **MANUAL**, **PUSH** using the **LEFT** or **RIGHT** button.

1. **ATW** : Color temperature is automatically adjusted to 2,000°K ~ 10,000°K
2. **MANUAL** : To set a certain color temperature with RED CONT, BLUE CONT
 - Select **MANUAL** using the **UP** or **DOWN** button and press the **MENU** button to activate **WB MANUAL** option.

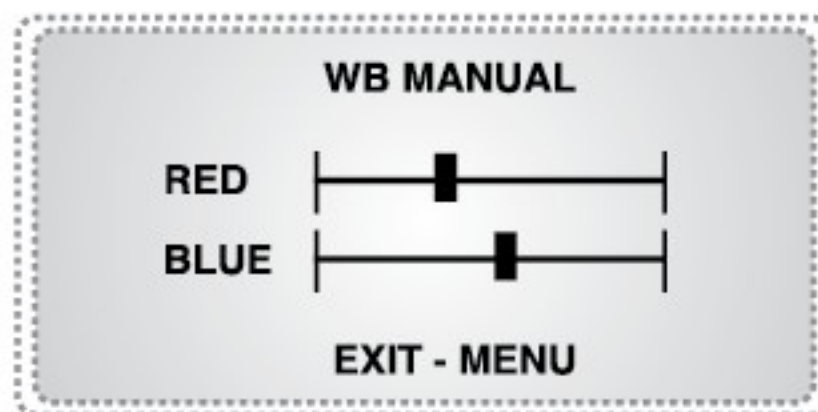

1. **RED** : To adjust density of RED (0~160)
2. **BLUE** : To adjust density of BLUE (0~ 160)

3. **PUSH** : If the set color temperature does not meet your environment, press the **MENU** button to adjust the color temperature to desired setting.

AGC (Automatic Gain Control)

Select AGC using the UP or DOWN button. You can select between OFF, ON using the LEFT or RIGHT button.

- 1. ON** : Select ON using the LEFT or RIGHT button and press the MENU button to activate AGC option.

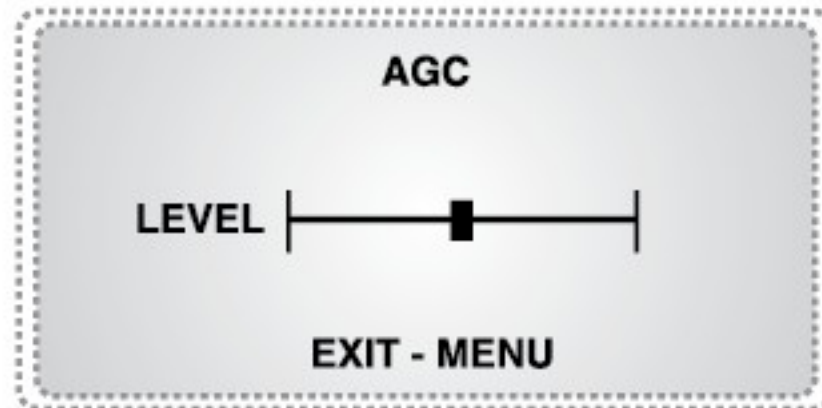

- 1. LEVEL** : You can adjust between 0 ~ 20 using the LEFT or RIGHT button.

- 2. OFF** : Disable the AGC

DAY / NIGHT

Select **DAY / NIGHT** using the **UP** or **DOWN** button. You can select between **AUTO**, **COLOR**, **B/W**, **EXT** using the **LEFT** or **RIGHT** button.

1. **COLOR** : for color mode only (DAY mode)
2. **B/W** : for BLACK and WHITE mode only (NIGHT mode)
 - Select B/W using the LEFT or RIGHT button and press the MENU button to activate COLOR BURST option.
3. **EXT** : To switch between COLOR or BLACK and WHITE depending on external signals.

NOTE: This function is not supported for this model. (Optional)

4. **AUTO** : To switch between COLOR or BLACK and WHITE automatically upon the illumination.
 - Select AUTO using the LEFT or RIGHT button and press MENU button to activate CHANGE DELAY TIME option.



It is possible to select ON/OFF using the LEFT or RIGHT button.



You can adjust the DELAY TIME from 1 ~ 15 using the LEFT or RIGHT button.



NOTE In Auto mode D&N camera using external IR may cause D&N filter to flicker.

IMAGE ADJ (Image Adjust)

Select **IMAGE ADJ** using the **UP** or **DOWN** button and press the **MENU** button to activate the **IMAGE ADJ** mode.

IMAGE ADJ	
SBLC	OFF
DNR	LOW
SHARPNESS	←
MIRROR	OFF
MOTION	←
PRIVACY	←
COLOR GAIN	←
INITIAL	ON
RETURN	←

- 1. SBLC (Super Back Light Compensation)** : To lighten a darker part of the image
 - Select SBLC using the UP or DOWN button. You can select between OFF, LOW, MIDDLE, HIGH using the LEFT or RIGHT button.
- 2. DNR (Digital Noise Reduction)** : To reduce the image noise especially during the low ambient lighting conditions.
 - Select DNR using the UP or DOWN button. You can adjust between OFF, LOW, MIDDLE, HIGH using the LEFT or RIGHT button.

3. SHARPNESS : To adjust SHARPNESS of the image.

- Select SHARPNESS using the UP or DOWN button.
- Select ← and press the MEUN button to activate SHARPNESS option.
- You can adjust the sharpness from 0~20 using the LEFT or RIGHT button.

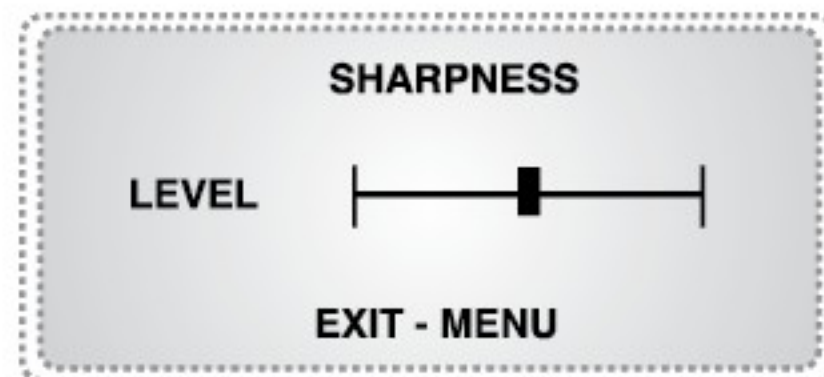

4. MIRROR

- Select MIRROR using the UP or DOWN button. You can select from ON/OFF using the LEFT or RIGHT button.
- (1) ON : Horizontal image flip.
- (2) OFF : default

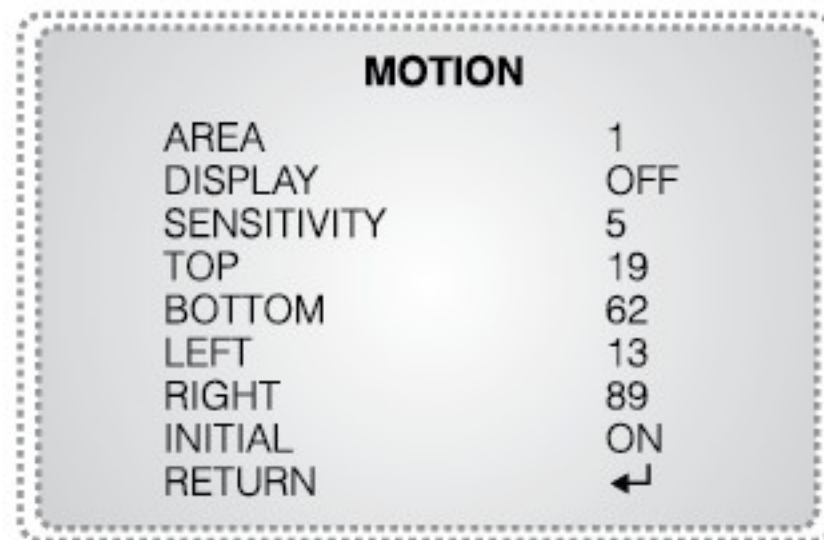

5. MOTION (Motion Detect)

- Select MOTION using the UP or DOWN button and press MENU button to activate MOTION DETECT option.

1) AREA : To specify MOTION DETECTION area

- Select AREA using the UP or DOWN button. You can select from area 1~4 position using the LEFT or RIGHT button.

**2) DISPLAY** : To display MOTION DETECTED area on the video

- Select DISPLAY using the UP or DOWN button. You can select between ON/OFF using the LEFT or RIGHT button.
 - (1) ON : display the MOTION DETECTED area on the screen
 - (2) OFF : disable

**3) SENSITIVITY** : To setup the motion sensitivity

- Select SENSITIVITY using the UP or DOWN button. You can adjust the motion sensitivity of a movement from 1~24 using the LEFT or RIGHT button.
 - (1) 1 : most sensitive (highest)
 - (2) 24 : least sensitive (lowest)

4) TOP / BOTTOM / LEFT / RIGHT : Users can specify MOTION DETECTED area.

- Select TOP, BOTTOM, LEFT, or RIGHT using the UP or DOWN button. You can adjust the AREA using the LEFT or RIGHT button.

(1) TOP : extend or reduce the upper area of the MOTION DETECTED area (8~126)

(2) BOTTOM : extend or reduce the bottom area of the MOTION DETECTED area (8~126)

(3) LEFT : extend or reduce the left side of the MOTION DETECTED area (4~191)

(4) RIGHT : extend or reduce the right side of the MOTION DETECTED area (4~191)

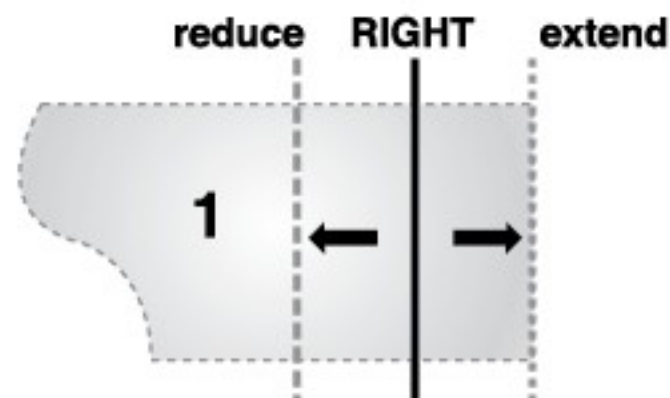
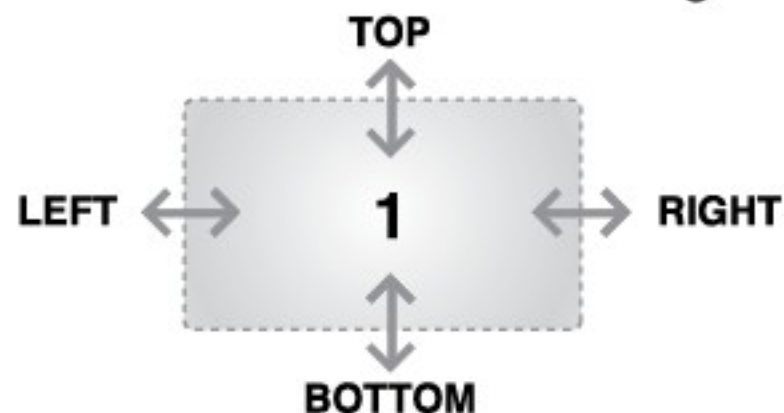

5) INITIAL : To reset the MOTION DETECT mode.

- Select INITIAL using the UP or DOWN button. You can reset the MOTION DETECT mode using the MENU button.

6) RETURN :To return to IMAGE ADJ MENU

- Select RETURN using the UP or DOWN button. You can return to IMAGE ADJ MENU using the MENU button.

6. PRIVACY

- Select PRIVACY using the UP or DOWN button and press the MENU button to active the PRIVACY option.

1) AREA : To specify the PRIVACY area

- Select AREA using the UP or DOWN button. You can select area from 1~4 position using the LEFT or RIGHT button.

2) DISPLAY : To display the Privacy Zone area

- Select DISPLAY using the UP or DOWN button. You can select between ON/OFF using the LEFT or RIGHT button.

(1) ON : display the Privacy Zone area

(2) OFF : disable

3) COLOR : To change color of privacy zone

- Select COLOR using the UP or DOWN button. You can adjust from WHITE, YELLOW, GREEN, BLUE, RED, BLACK, or GRAY using the LEFT or RIGHT button.

PRIVACY	
AREA	1
DISPLAY	OFF
COLOR	WHITE
TOP	15
BOTTOM	31
LEFT	44
RIGHT	104
INITIAL	ON
RETURN	←



4) TOP / BOTTOM / LEFT / RIGHT : Users can specify PRIVACY ZONE area

- Select TOP, BOTTOM, LEFT, or RIGHT using the UP or DOWN button. You can adjust the privacy zone using the LEFT or RIGHT button.

- (1) TOP : extend or reduce the upper area of the MOTION DETECTED area (4~63)
- (2) BOTTOM : extend or reduce the bottom area of the MOTION DETECTED area (5~64)
- (3) LEFT : extend or reduce the left side of the MOTION DETECTED area (18~205)
- (4) RIGHT : extend or reduce the right side of the MOTION DETECTED area (19~206)

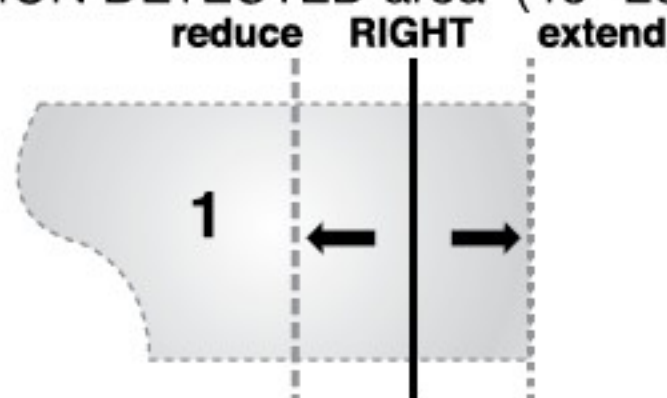
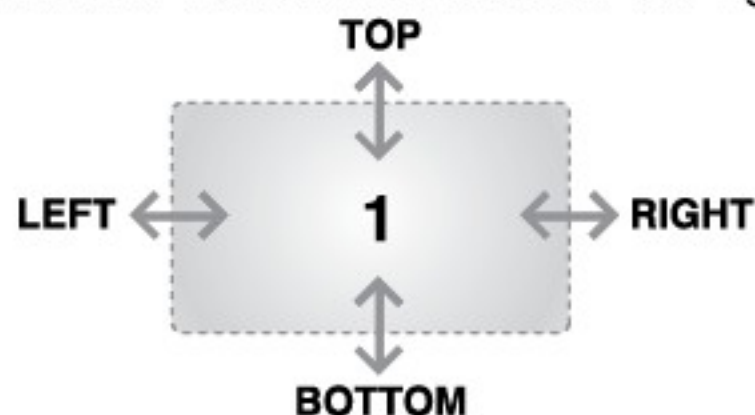

5) INITIAL : To reset to factory default only on the PRIVACY mode.

- Select INITIAL using the UP or DOWN button. You can reset the PRIVACY mode using the MENU button.

6) RETURN : To return to IMAGE ADJ MENU

- Select RETURN using the UP or DOWN button. You can return to IMAGE ADJ MENU using the MENU button.

7. COLOR GAIN

- Select COLOR GAIN using the UP or DOWN button and press MENU button to activate COLOR MODE option.

8. INITIAL :

- To reset to factory default only on the IMAGE ADJ mode.
- Select INITIAL using the UP or DOWN button and reset the IMAGE ADJ mode using the MENU button.

9. RETURN :

- To return to MAIN MENU
- Select RETURN using the UP or DOWN button and return to MENU using the MENU button.

GENERAL

Select **GENERAL** using the UP or DOWN button and press the MENU button to activate the **GENERAL** mode.

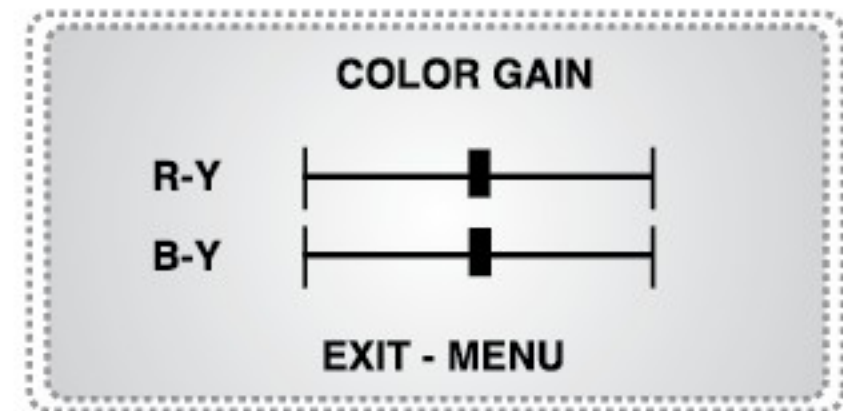

1. R-Y : To adjust density of RED (0~20)
2. B-Y : To adjust density of BLUE (0~20)

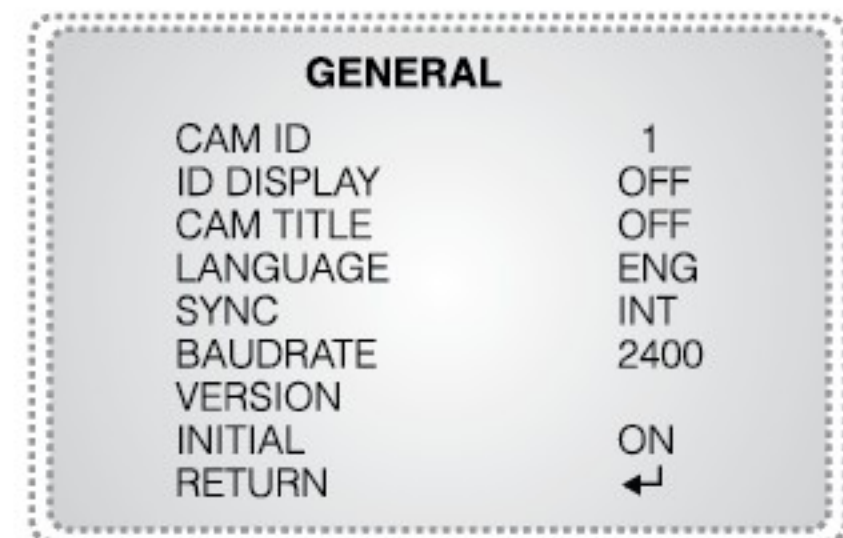

1. CAM ID : CAMERA ID (RS-485 Communication ID)

- Select CAM ID using the UP or DOWN button. You can select between the range 000~255 using the LEFT or RIGHT button.

NOTICE : CAM ID does not reset after user setting.

2. ID DISPLAY (CAMERA ID DISPLAY)

- Select ID DISPLAY using the UP or DOWN button. You can select between ON/OFF using the LEFT or RIGHT button.

- (1) ON : To display camera ID on the screen
- (2) OFF : disable

3. CAM TITLE

- Select CAM TITLE using the UP or DOWN button.
You can adjust ON/OFF using the LEFT or RIGHT button.

- (1) ON : To display the camera title on the screen
- (2) OFF : disable

- Select ON and Press MENU button to display CAM TITLE.

- (1) UP/DN : To select character using the UP or DOWN button (0~9,A~Z)
- (2) LE/RI : To select position using the LEFT or RIGHT button.

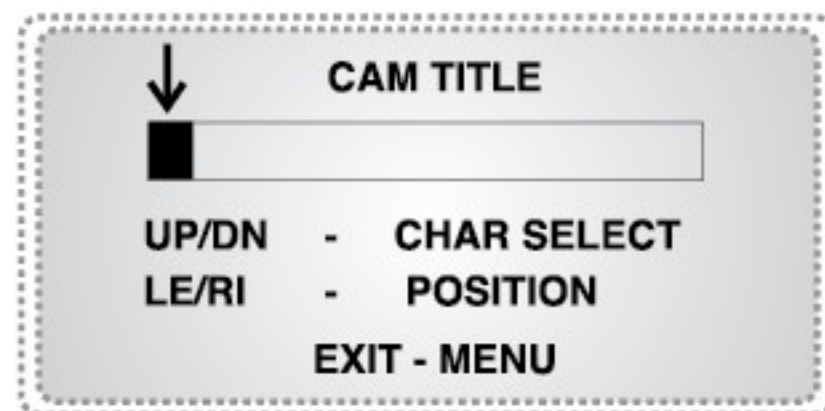

4. LANGUAGE - Select LANGUAGE using the UP or DOWN button. You can change between ENG or CHN using the LEFT or RIGHT button.

5. SYNC - Internal Synchronization Type : INT

6. BAUDRATE - Select BAUDRATE using the UP or DOWN button. You can change from 2400bps, 4800bps 9600bps, 57600bps using the LEFT or RIGHT button.

7. VERSION

8. INITIAL : To reset to factory default only on the GENERAL mode.

- Select INITIAL using the UP or DOWN button. You can reset to factory default for GENERAL mode using the MENU button.

9. RETURN : To return to MENU

- Select RETURN using the UP or DOWN button. You can return to the MENU using the MENU button.

INITIAL : To reset to factory default.

- Select INITIAL using the UP or DOWN button and reset to factory default using the MENU button.

EXIT : To exit out from the OSD setup menu.

- Select EXIT using the UP or DOWN button and close the OSD setup menu by pressing MENU button.

MODEL	HIGH RESOLUTION		NORMAL RESOLUTION	
	NTSC	PAL	NTSC	PAL
Signal System	NTSC	PAL	NTSC	PAL
Image Sensor	1/3 interline CCD			
Effective Pixels	768(H)x494(V)	752(H)x582(V)	510(H)x492(V)	500(H)x582(V)
Video Output	Composite : 1.0V p-p, 75Ω			
Sync. System	Internal Sync			
Luminance S/N Ratio	50dB Min.(AGC off)			
Horizontal Resolution	600 TVLines (BW 650 TVLines)		400 TVLines (BW 420 TVLines)	
Sensitivity	0.1 Lux (color) / 0.01 Lux (B/W)		0.05 Lux (color) / 0.005 Lux (B/W)	
ESC	(NTSC-1/ 60 ~ 1/ 120,000), (PAL - 1/ 50 ~1/ 120,000)			
Manual Shutter	1/ 60(1/50), 1/120(1/100), 1/ 250, 1/ 500, 1/ 700, 1/ 1K, 1/ 1.6K, 1/ 2.5K, 1/ 5K, 1/ 7K, 1/ 10K, 1/ 30K, 1/ 60K, 1/ 120K			
DNR	OFF, LOW, MIDDLE, HIGH			
White Balance	ATW, MANUAL , PUSH			
SBLC	OFF, LOW, MIDDLE, HIGH			

AGC	ON, OFF
Day / Night	AUTO, COLOR, B/W, EXT
Burst	ON, OFF
Motion Detection	ON, OFF (4 Programmable Zone)
Privacy	ON, OFF (4 Programmable Zone)
Mirror	ON(HORIZONTAL), OFF
Sharpness	1 ~ 20
Communication	RS-485 (Pelco-D, CNB)
OSD Language	English / Chinese
Applicable Lens	DC Iris / Manual Lens
Supply Voltage	12V DC (+10% -20%)
Power Consumption	180mA / 2.2W (Max)
Operating Temperature/ Humidity	-10°C to +50°C / 30% to 80% RH
Storage Temperature/ Humidity	-20°C to +60°C / 20% to 90% RH

COLOR DOME CAMERA
**24VAC / 12VDC
Input Model**

MODEL	HIGH RESOLUTION		NORMAL RESOLUTION	
Signal System	NTSC	PAL	NTSC	PAL
Image Sensor	1/3 interline CCD			
Effective Pixels	768(H)x494(V)	752(H)x582(V)	510(H)x492(V)	500(H)x582(V)
Video Output	Composite : 1.0V p-p, 75Ω			
Sync. System	Internal Sync			
Luminance S/N Ratio	50dB Min.(AGC off)			
Horizontal Resolution	600 TVLines (BW 650 TVLines)		400 TVLines (BW 420 TVLines)	
Sensitivity	0.1 Lux (color) / 0.01 Lux (B/W)		0.05 Lux (color) / 0.005Lux (B/W)	
ESC	(NTSC-1/ 60 ~ 1/ 120,000), (PAL - 1/ 50 ~1/ 120,000)			
Manual Shutter	1/ 60(1/50), 1/120(1/100), 1/ 250, 1/ 500, 1/ 700, 1/ 1K, 1/ 1.6K, 1/ 2.5K, 1/ 5K, 1/ 7K, 1/ 10K, 1/ 30K, 1/ 60K, 1/ 120K			
DNR	OFF, LOW, MIDDLE, HIGH			
White Balance	ATW, MANUAL , PUSH			
SBLC	OFF, LOW, MIDDLE, HIGH			

24VAC / 12VDC
Input Model

AGC	ON, OFF
Day / Night	AUTO, COLOR, B/W, EXT
Burst	ON, OFF
Motion Detection	ON, OFF (4 Programmable Zone)
Privacy	ON, OFF (4 Programmable Zone)
Mirror	ON(HORIZONTAL), OFF
Sharpness	1 ~ 20
Communication	RS-485 (Pelco-D, CNB)
OSD Language	English / Chinese
Applicable Lens	DC Iris / Manual Lens
Supply Voltage	24V AC (20V~28V), 12V DC(11V~15V)
Power Consumption	0.3A / 3.6W (Max)
Operating Temperature/ Humidity	-10°C to +50°C / 30% to 80% RH
Storage Temperature/ Humidity	-20°C to +60°C / 20% to 90% RH

◎ 11. TROUBLESHOOTING

If you have trouble operating your camera, refer to the following guidelines. If the guidelines do not help you to solve the problem, contact an authorized technician.

Nothing appears on the screen

- Check that the power cord and line connection between the camera and monitor are fixed properly.
- Check that you have properly connected VIDEO cable to the camera VIDEO output jack.

The image on the screen is dim

- Is lens stained with dirt? Clean your lens with soft, clean cloth.
- Set the monitor to proper condition.
- If the camera is exposed to too strong light, change the camera position.
- Adjust the lens' focus properly.

The image on the screen is dark

- Adjust the contrast feature of the monitor.
- If you have an intermediate device, set the 75Ω / Hi-z properly.
- Adjust DC Level, VR level properly.

The camera is not working properly, and the surface of the camera is hot.

- Check that you have properly connected the camera to an appropriate power source.

The image on the screen flickers.

- Check whether the camera is exposed to strong sunlight or fluorescent lighting.

◎ MEMO

MEMO

COLOR DOME CAMERA

DIGITAL DOME CAMERA SERIES

P/N : 3810-0185F (Ver.0909E)

Design and specifications are subject to change without notice.

